

Surname	Centre Number	Candidate Number
Other Names		0



GCSE

3300U50-1



**MATHEMATICS
UNIT 1: NON-CALCULATOR
HIGHER TIER**

FRIDAY, 10 NOVEMBER 2017 – MORNING

1 hour 45 minutes

ADDITIONAL MATERIALS

The use of a calculator is not permitted in this examination.
A ruler, a protractor and a pair of compasses may be required.

INSTRUCTIONS TO CANDIDATES

Use black ink or black ball-point pen. Do not use gel pen or correction fluid.

You may use a pencil for graphs and diagrams only.

Write your name, centre number and candidate number in the spaces at the top of this page.

Answer **all** the questions in the spaces provided.

If you run out of space use the continuation page at the back of the booklet. Question numbers must be given for all work written on the continuation page.

Take π as 3.14.

INFORMATION FOR CANDIDATES

You should give details of your method of solution when appropriate.

Unless stated, diagrams are not drawn to scale.

Scale drawing solutions will not be acceptable where you are asked to calculate.

The number of marks is given in brackets at the end of each question or part-question.

In question 4, the assessment will take into account the quality of your linguistic and mathematical organisation and communication.

For Examiner's use only		
Question	Maximum Mark	Mark Awarded
1.	3	
2.	5	
3.	4	
4.	7	
5.	4	
6.	3	
7.	5	
8.	3	
9.	4	
10.	4	
11.	3	
12.	9	
13.	5	
14.	2	
15.	4	
16.	3	
17.	4	
18.	1	
19.	7	
Total	80	



NOV173300U50101

Formula List - Higher Tier

Area of trapezium = $\frac{1}{2}(a + b)h$

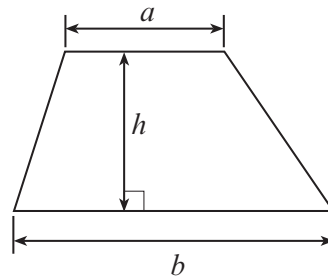

Volume of prism = area of cross-section \times length

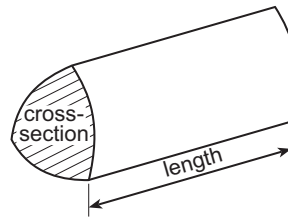

Volume of sphere = $\frac{4}{3}\pi r^3$

Surface area of sphere = $4\pi r^2$

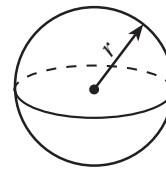

Volume of cone = $\frac{1}{3}\pi r^2 h$

Curved surface area of cone = $\pi r l$

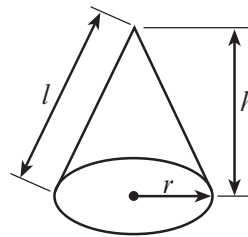

In any triangle ABC

Sine rule $\frac{a}{\sin A} = \frac{b}{\sin B} = \frac{c}{\sin C}$

Cosine rule $a^2 = b^2 + c^2 - 2bc \cos A$

Area of triangle = $\frac{1}{2}ab \sin C$

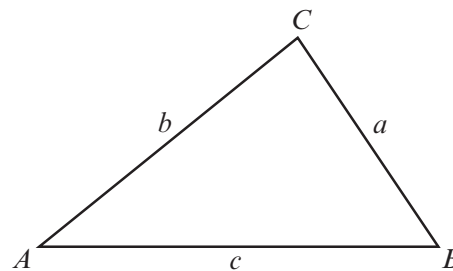

The Quadratic Equation

The solutions of $ax^2 + bx + c = 0$ where $a \neq 0$ are given by $x = \frac{-b \pm \sqrt{(b^2 - 4ac)}}{2a}$

Annual Equivalent Rate (AER)

AER, as a decimal, is calculated using the formula $\left(1 + \frac{i}{n}\right)^n - 1$, where i is the nominal interest rate per annum as a decimal and n is the number of compounding periods per annum.



1. Look at the following descriptions of special quadrilateral shapes.
Circle the correct name for each one.

(a) Its diagonals intersect at 90° .
Only one diagonal is a line of symmetry. [1]

Kite Rhombus Square Trapezium Rectangle

(b) Only one pair of sides are parallel. [1]

Kite Rhombus Square Trapezium Rectangle

(c) All four sides are equal.
Its diagonals are not equal in length. [1]

Kite Rhombus Square Trapezium Rectangle



2. (a) Complete the table below.
 Draw the graph of $y = 2x^2 - 5$ for values of x between -2 and 3 .
 Use the graph paper below.
 Choose a suitable scale for the y -axis.

[4]

x	-2	-1	0	1	2	3
$y = 2x^2 - 5$	3		-5	-3	3	13

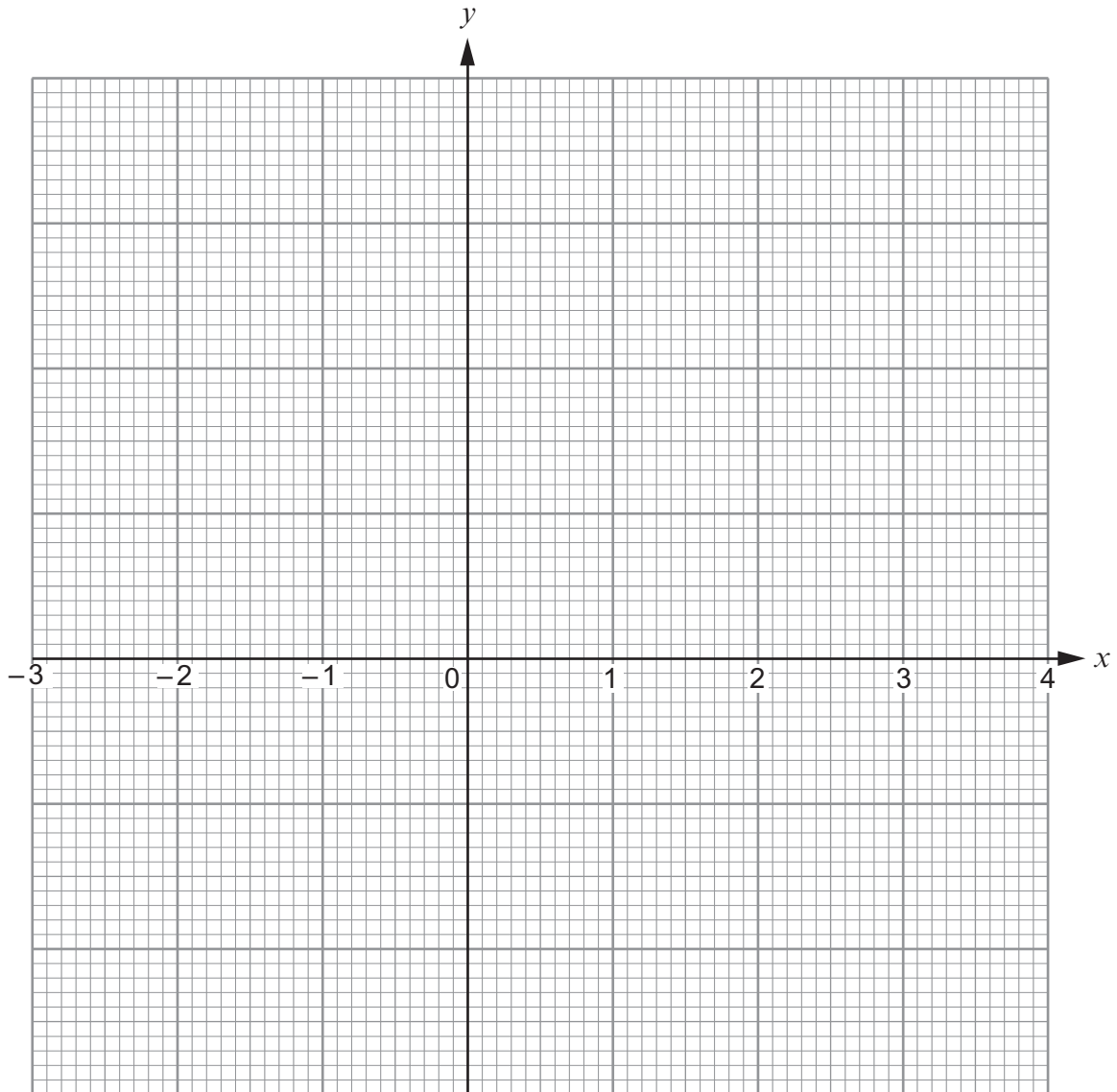

(b)

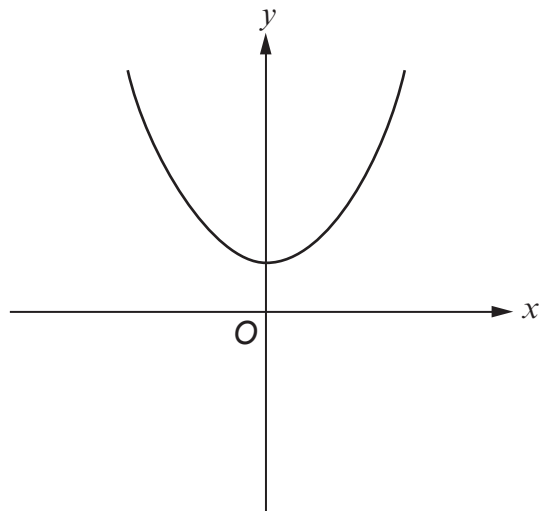

The sketch above can represent only one of the equations given below.
Circle this equation.

[1]

$y = x^2$

$y = x^2 - 3$

$y = -x^2$

$y = x^2 + 3$

$y = 3x$



3. (a) Rotate triangle A through 90° anticlockwise, about the point $(-2, 3)$.

[2]

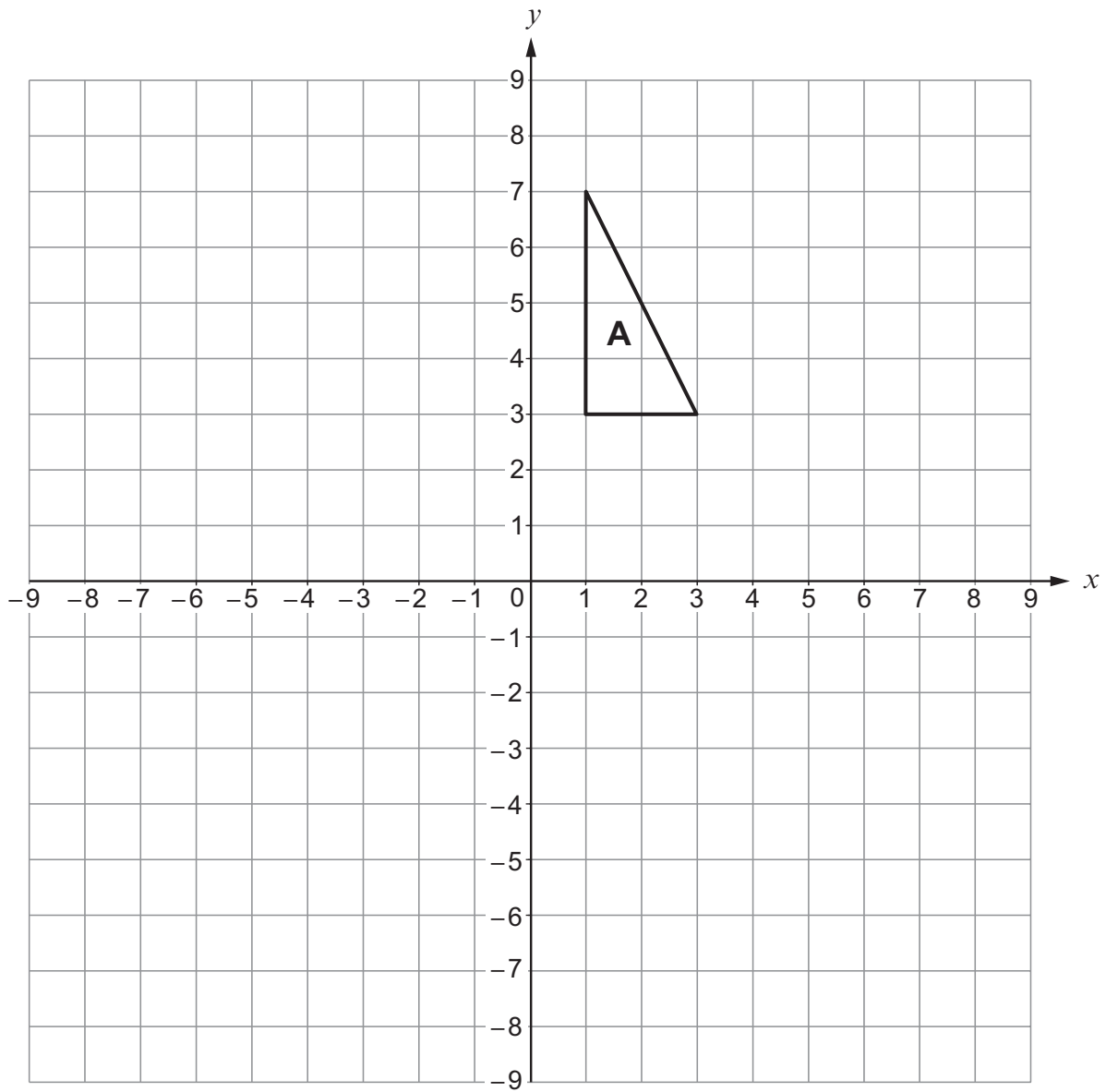

- (b) Enlarge triangle B by a scale factor of $\frac{1}{2}$, using (0, 0) as the centre of enlargement. [2]

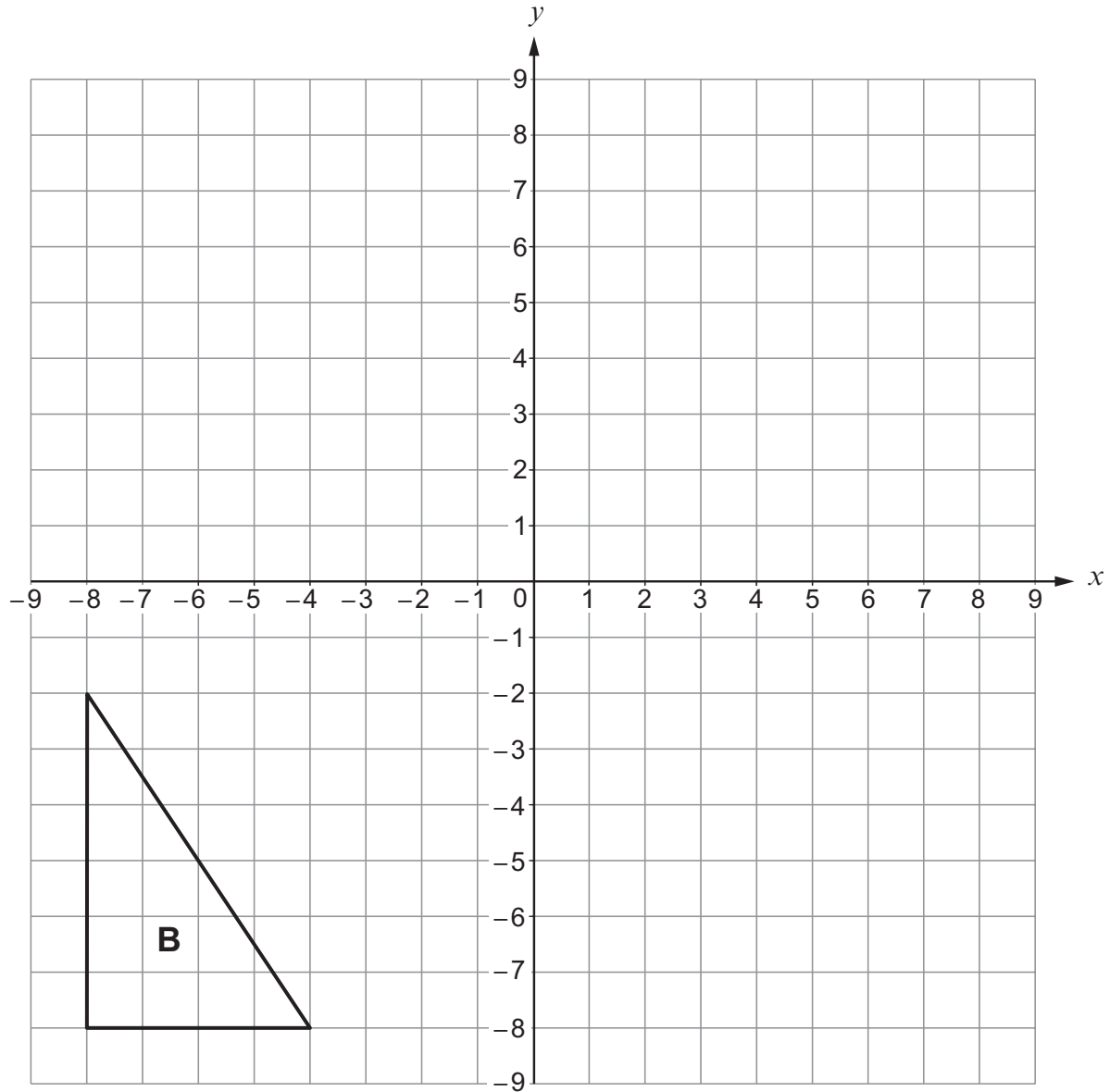

4. In this question you will be assessed on the quality of your organisation, communication and accuracy in writing.

PQ and PR are tangents to a circle with centre O .

$$\widehat{RPQ} = 30^\circ.$$

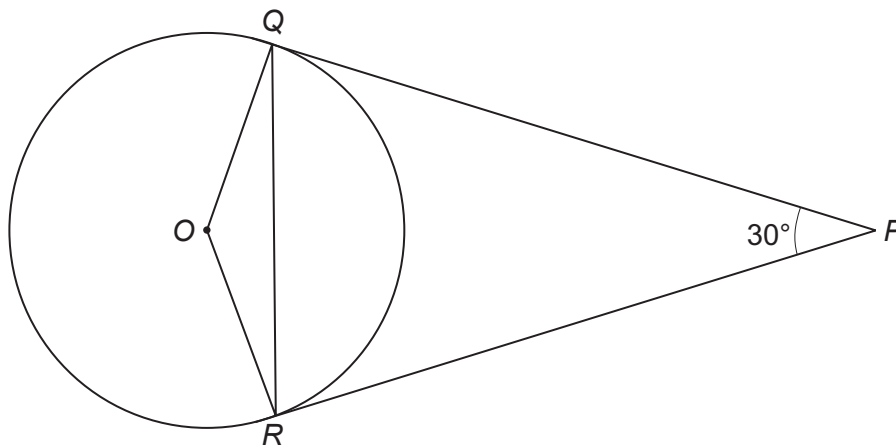

Diagram not drawn to scale

Find the size of \widehat{OQR} .

You must indicate any angles you calculate.

You must give a reason for each stage of your working.

[5 + 2 OCW]

.....

.....

.....

.....

.....

.....

.....

.....

.....

.....

.....

.....

.....

.....

.....

.....

.....

.....

.....

.....

.....

.....

$$\widehat{OQR} = \dots\dots\dots^\circ$$



5. (a) Express 0.00042 in standard form. [1]

.....

(b) Calculate the value of $\frac{7.2 \times 10^6}{2 \times 10^{-2}}$.

Give your answer in standard form. [1]

.....

.....

(c) Calculate the value of $(4.7 \times 10^5) - (6.2 \times 10^4)$.
Give your answer in standard form. [2]

.....

.....

.....

.....



6. Using only a ruler and a pair of compasses, construct a perpendicular line from the point P to the line AB . [3]

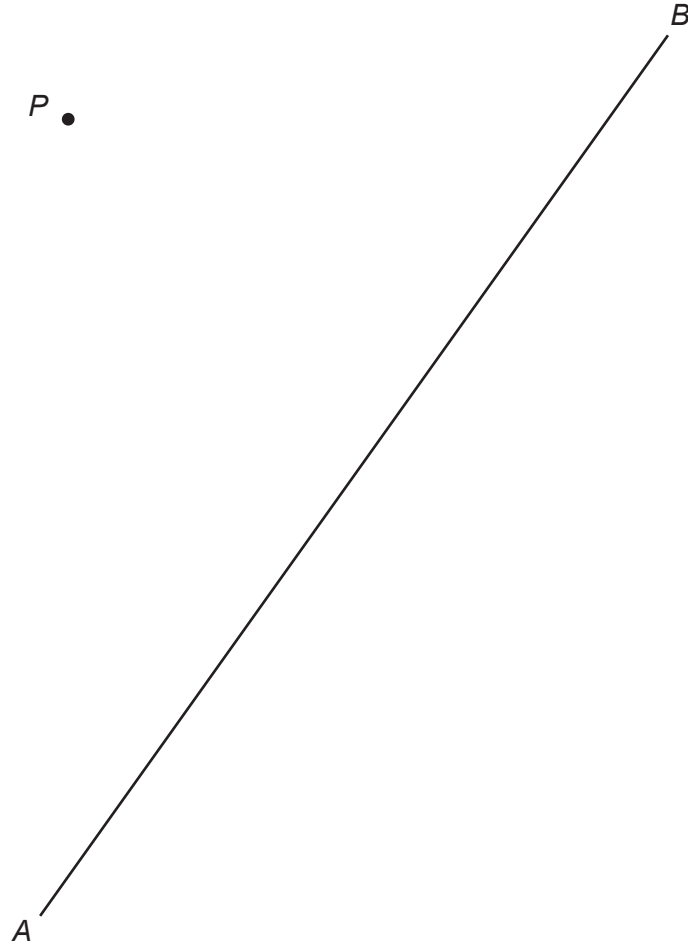

7. A group of pupils from a school took part in The Urdd National Eisteddfod. **All** of them competed in at least one of the following competitions: *Singing*, *Dancing* or *Reciting*.

- 2 of them only took part in a *Dancing* competition.
- 5 only took part in a *Reciting* competition.
- No one took part in both a *Reciting* and a *Dancing* competition.
- 3 took part in both a *Singing* and a *Dancing* competition.
- 9 took part in a *Reciting* competition.
- 22 took part in a *Singing* competition.

The Venn diagram below shows some of the above information. The universal set, \mathcal{E} , contains all of the pupils in the group.

One of the pupils in the group is chosen at random. What is the probability that this person **only** took part in a *Singing* competition? [5]

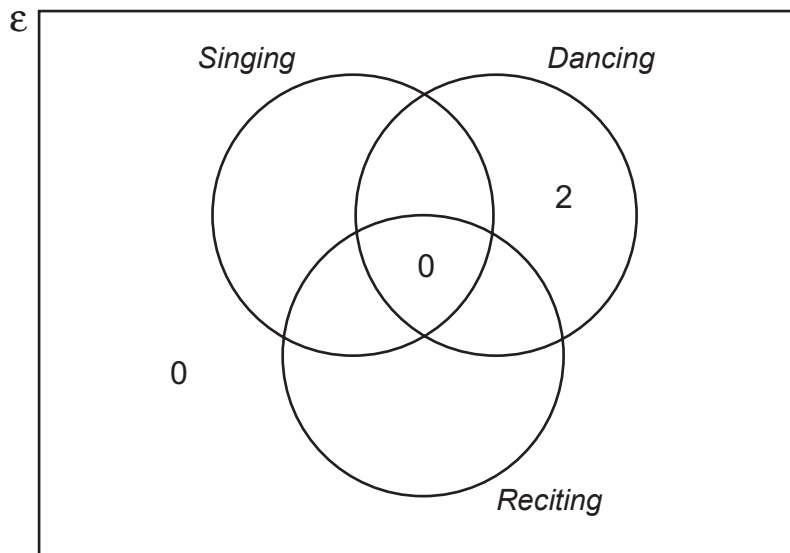

.....

.....

.....

.....

.....

.....



8. Factorise $x^2 - 7x - 18$, and hence solve $x^2 - 7x - 18 = 0$.

[3]

.....

.....

.....

.....

.....

.....

.....

.....



9. Solve the following simultaneous equations using an algebraic (not graphical) method. [4]

$$4x - 3y = 2$$

$$6x - 5y = 1$$

Dotted lines for working out the solution.



10. A cylinder just fits inside a hollow cube with sides of length m cm.

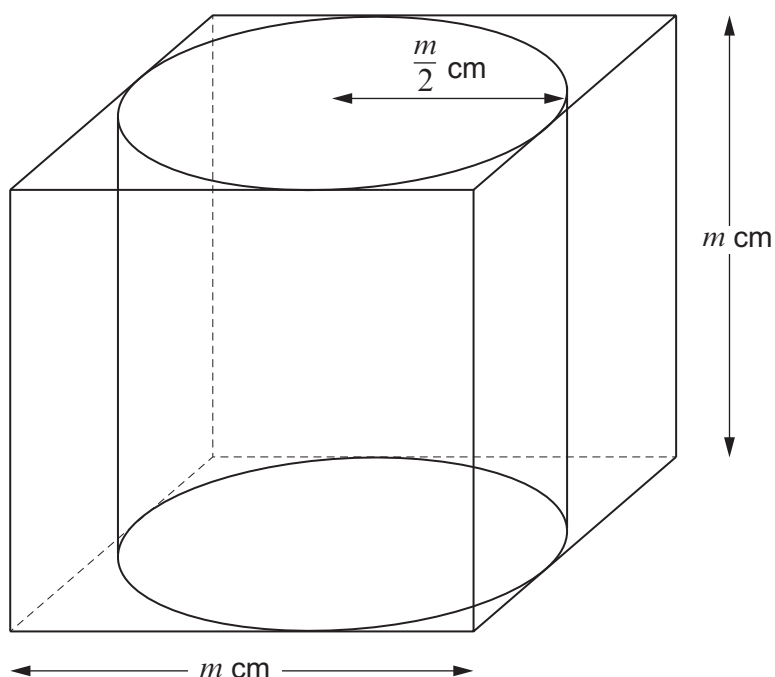

Diagram not drawn to scale

The radius of the cylinder is $\frac{m}{2}$ cm.

The height of the cylinder is m cm.

The ratio of the volume of the cube to the volume of the cylinder is given by

volume of cube : volume of cylinder

$$= k : \pi,$$

where k is a number.

Find the value of k .

You must show all your working.

[4]

.....

.....

.....

.....

.....



Examiner
only

.....

.....

.....

.....

.....

.....

.....

.....

.....

.....

.....



11.

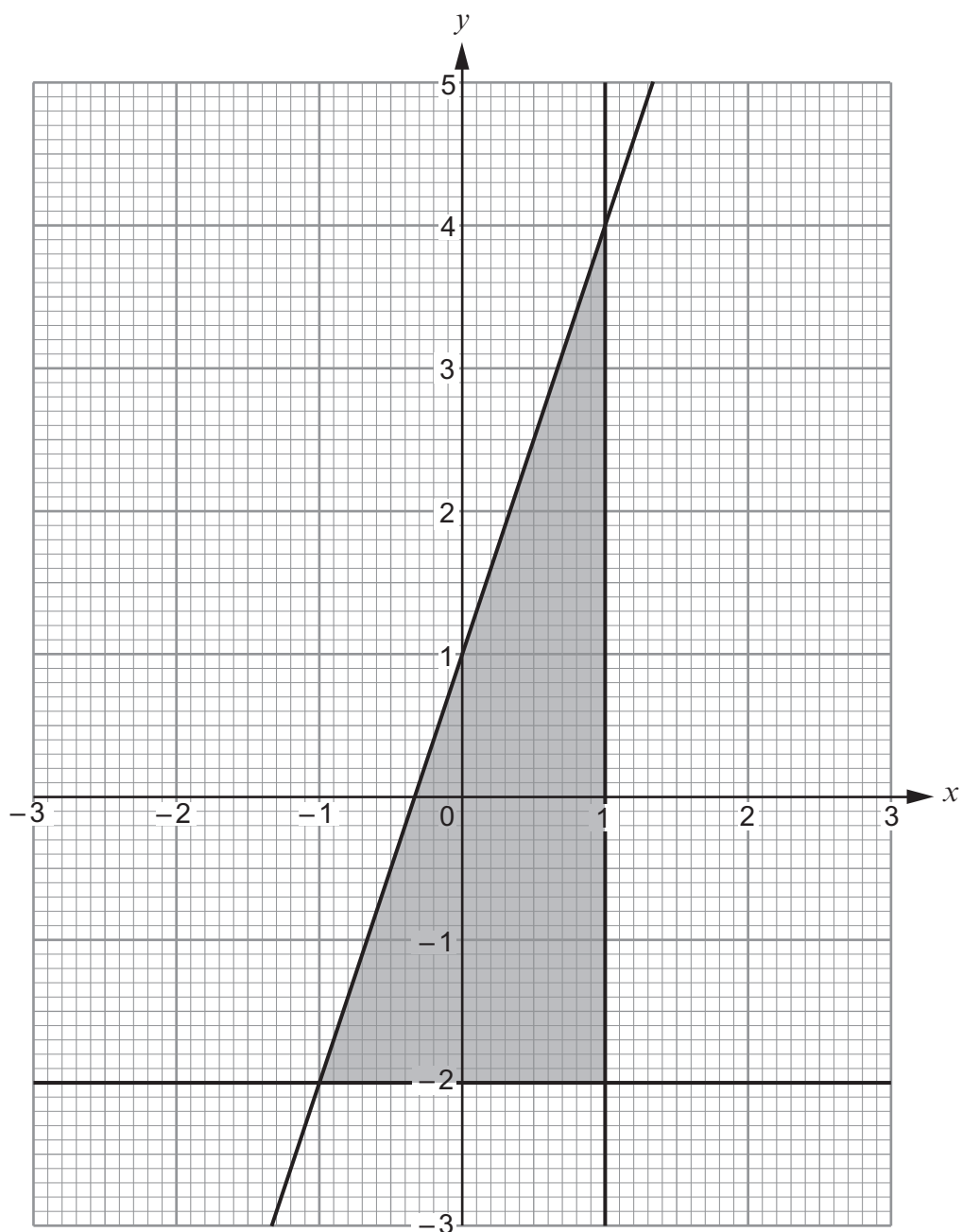

Complete the following table to give the set of inequalities that describes the shaded region shown above. [3]

.....

$x \leq 1$



12. Two different squares are constructed.
The side length of the smaller square is x cm.
The side length of the larger square is 3 cm longer than the side length of the smaller square.
The combined area of the two squares is 22.5 cm^2 .

(a) Show that $4x^2 + 12x - 27 = 0$. [4]

.....

.....

.....

.....

.....

.....

.....

.....

.....

(b) Find the dimensions of each of the squares.
Do **not** use a trial and improvement method.
You must show all your working and **justify** any decision that you make. [5]

.....

.....

.....

.....

.....

.....

.....

.....

.....

.....

.....

.....

.....

.....

.....

.....

.....

.....

.....

.....

.....

.....

Side length of smaller square = cm

Side length of larger square = cm



13. Given that y is inversely proportional to x^3 and that $y = 120$ when $x = 2$,

(a) find an expression for y in terms of x ,

[3]

.....

.....

.....

.....

.....

.....

.....

.....

(b) use the expression you found in part (a) to complete the following table.

[2]

x	2	10	
y	120		15

.....

.....

.....

.....

.....

.....

.....

.....

.....

.....

.....

.....

.....

.....

.....

.....

.....

.....

.....

.....



14. The two triangles shown below are not drawn to scale.

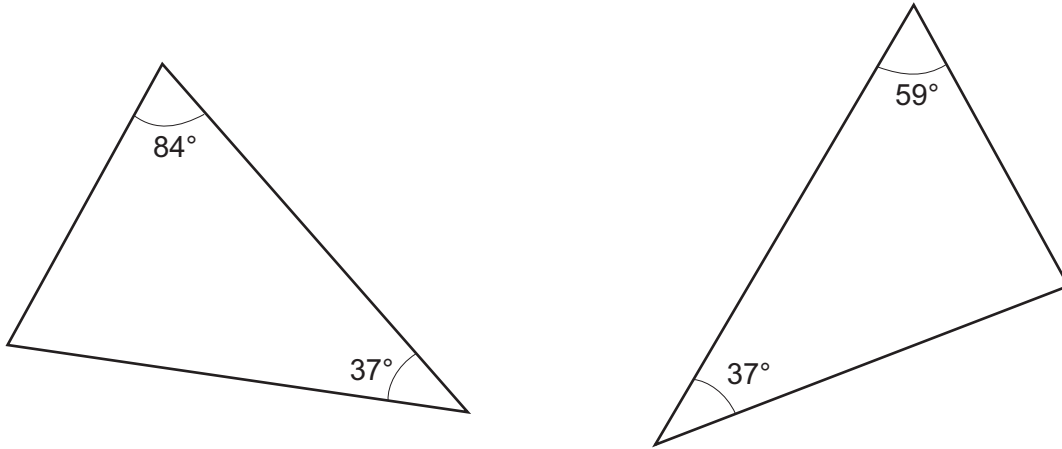

Which **one** of the following statements is correct?
Give full reasons for your answer.

[2]

- | |
|---|
| A: the triangles must be congruent |
| B: the triangles could be congruent |
| C: the triangles cannot be congruent |

.....

.....

.....

The correct statement is

This is because

.....

.....

.....

.....



15. (a) Express $0.6\dot{4}\dot{2}$ as a fraction.

[2]

.....

.....

.....

.....

.....

.....

.....

.....

(b) Evaluate $\left(\frac{1}{36}\right)^{-\frac{1}{2}}$.

[2]

.....

.....

.....

.....

.....

.....



16. You are given that $p = \sqrt{40}$ and $q = \sqrt{10}$.
Circle the correct answer in each of the following:

(a) p is equal to

[1]

$10\sqrt{4}$

$4\sqrt{10}$

$10\sqrt{2}$

$2\sqrt{10}$

20

.....

.....

.....

(b) pq is equal to

[1]

$10\sqrt{40}$

$40\sqrt{10}$

400

200

20

.....

.....

.....

(c) q^5 is equal to

[1]

$100\sqrt{10}$

$5\sqrt{10}$

$\sqrt{50}$

625

$10\sqrt{100}$

.....

.....

.....

.....

.....



17. Simplify $\frac{12x+16}{9x^2-16}$.

[4]

.....

.....

.....

.....

.....

.....

.....

.....



18. The following diagram shows a sketch of the curve $y = f(x)$.

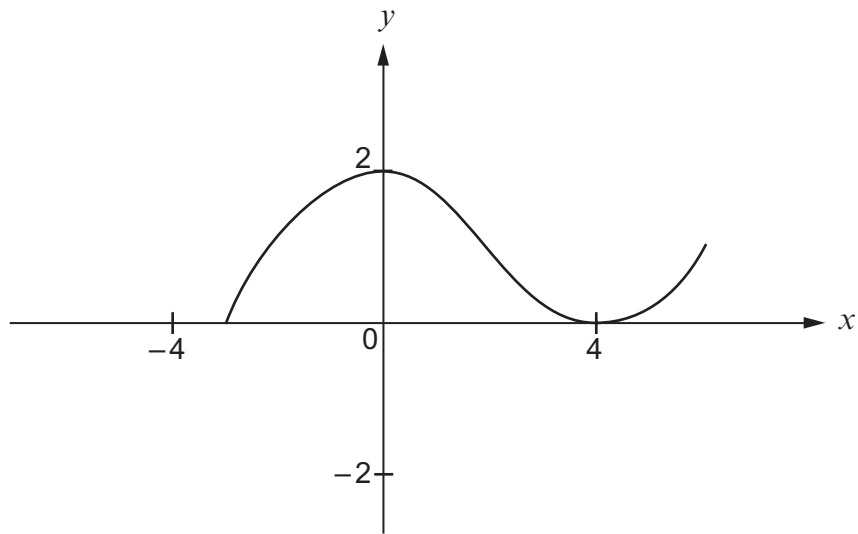

The curve is transformed, as shown below.

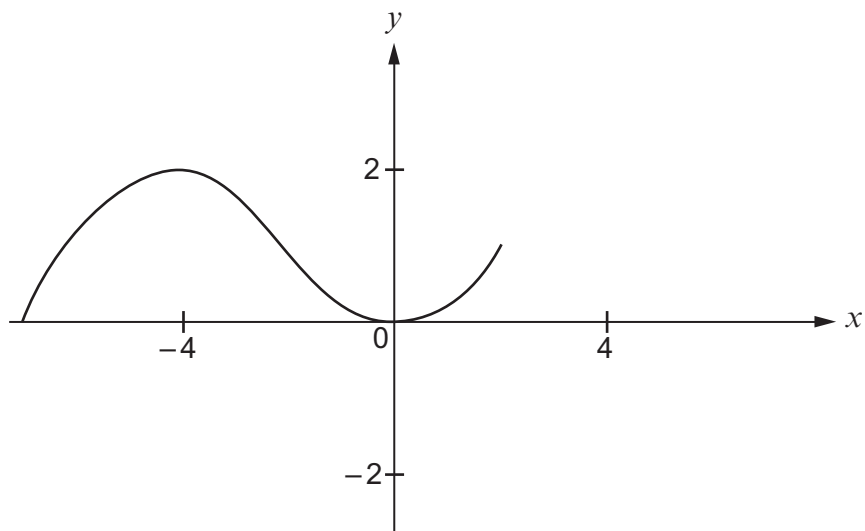

Using function notation, complete the following to give the equation of the transformed curve. [1]

The equation of the transformed curve is

$$y = \dots\dots\dots$$



19.



Two of the cards shown above are selected at random, without being replaced.

Find the probability that

- (a) the product of the two numbers selected is 12, [3]

.....

.....

.....

.....

.....

.....

.....

.....

.....

.....

- (b) the **sum** of the two numbers selected is **even**. [4]

.....

.....

.....

.....

.....

.....

.....

.....

.....

.....

END OF PAPER



BLANK PAGE

**PLEASE DO NOT WRITE
ON THIS PAGE**



BLANK PAGE

**PLEASE DO NOT WRITE
ON THIS PAGE**



BLANK PAGE

**PLEASE DO NOT WRITE
ON THIS PAGE**

