

Name	Date started	Target end date

## WJEC GCSE Mathematics and Numeracy (Double Award) – Question Pack

Simplifying surds, rationalising denominators, and using surds in exact calculations. Sourced from legacy WJEC GCSE Mathematics and Mathematics-Numeracy

**REVISE**  
*.wales*

## 2.05 – Surds

### *Spec 1.9.4, 1.9.5, 1.9.7 – Unit 2 (no calculator)*

*Simplifying surds, rationalising denominators, and using surds in exact calculations. Sourced from legacy WJEC GCSE Mathematics and Mathematics-Numeracy Higher non-calculator papers, organised for revision under the 2025 spec.*

**2025 SPECIFICATION**

### **Estimated time for entire question pack: ~1 hours 10 minutes**

*Derived from the GCSE Higher pace of ~1.5 min/mark (47 marks across 11 questions).*

*You are advised to **not** attempt to complete all of this in one sitting.*

### **ABOUT THIS QUESTION PACK**

This is a **focused single-topic practice pack**, not a single mock paper. Questions are organised against the 2025 specification. Questions are ordered chronologically by sitting, with custom-written and SAM questions at the end.

### **INSTRUCTIONS**

Use black ink or black ball-point pen. Show all working – method marks are awarded for clear setup.

*A calculator is **not** permitted on any question in this pack (Unit 2 is the non-calculator paper).*

*All question content is © WJEC CBAC Ltd. and reproduced for revision purposes only.*

# Surds – what the new spec asks

WJEC GCSE Mathematics (first teaching 2025) · Unit 2: non-calculator.

## Surd manipulation 1.9.4

- $\sqrt{a}\sqrt{b} = \sqrt{ab}$  and  $\sqrt{a}\sqrt{a} = a$ .
- Simplify by extracting the largest square factor.
- Like terms only when adding/subtracting surds.

## More complex surd expressions 1.9.5

- Multiply expressions containing surds – expand brackets carefully.
- Simplify fractions containing surds by dividing common factors.
- Multiply top & bottom by  $\sqrt{a}$  or the conjugate to rationalise.

## Surds in exact calculations 1.9.7

- Leave answers in surd form when an exact value is asked for.
- Useful in Pythagoras, areas, and geometric exact answers.
- Simplify to  $a\sqrt{b}$  with the smallest possible  $b$ .

## Rational vs irrational 1.9.4

- $\sqrt{n}$  is rational iff  $n$  is a perfect square.
- Sum of rational + irrational is irrational.
- Product of two irrationals can be rational, e.g.  $\sqrt{2} \cdot \sqrt{2} = 2$ .

# Surds in one page

Quick-reference notes – revisit before each question. Don't use during the questions.

## Surd basics

$$\sqrt{a} \times \sqrt{b} = \sqrt{ab}, \quad \sqrt{a} \times \sqrt{a} = a$$

$$\sqrt{3} \times \sqrt{12} = \sqrt{36} = 6.$$

$$\sqrt{5} \times \sqrt{5} = 5.$$

## Simplify by extracting squares

$\sqrt{ab} = \sqrt{a} \cdot \sqrt{b}$  — pull out the largest square factor

$$\sqrt{50} = \sqrt{25 \cdot 2} = 5\sqrt{2}.$$

$$\sqrt{72} = \sqrt{36 \cdot 2} = 6\sqrt{2}.$$

## Add & subtract surds

Only combine *like* surds (same radicand).

$$3\sqrt{2} + 5\sqrt{2} = 8\sqrt{2}.$$

$$\sqrt{18} + \sqrt{8} = 3\sqrt{2} + 2\sqrt{2} = 5\sqrt{2}.$$

## Expand brackets with surds

$$(2 + \sqrt{5})^2 = 4 + 4\sqrt{5} + 5 = 9 + 4\sqrt{5}.$$

$(\sqrt{a} + \sqrt{b})(\sqrt{a} - \sqrt{b}) = a - b$  — the 'difference of two squares' trick.

## Rationalise the denominator

$$\frac{1}{\sqrt{a}} = \frac{\sqrt{a}}{a}$$

$$\frac{4}{11\sqrt{5}} = \frac{4\sqrt{5}}{11 \times 5} = \frac{4\sqrt{5}}{55}.$$

For  $\frac{1}{a \pm \sqrt{b}}$ , multiply top & bottom by  $a - \sqrt{b}$ .

## Rational vs irrational answer

$\sqrt{n}$  is irrational unless  $n$  is a perfect square.

$3 + \sqrt{2}$  is irrational;  $(\sqrt{3})^2 = 3$  is rational.

State explicitly when asked.

## Exact answers in $\pi$

$$\text{circle: } C = 2\pi r, A = \pi r^2$$

Area of circle radius 3:  $9\pi$  (exact). Don't evaluate  $\pi$ .

Sector:  $A = \frac{\theta}{360}\pi r^2$ . Leave  $\pi$  in the answer.

## Volume & surface in $\pi$

$$\text{sphere: } V = \frac{4}{3}\pi r^3, SA = 4\pi r^2$$

Cone curved surface:  $\pi r l$  where  $l$  is slant height.

Cylinder volume:  $\pi r^2 h$ .

## Common traps

- $\sqrt{a} + \sqrt{b} \neq \sqrt{a+b}$ .

- Forgetting to simplify  $\sqrt{50} \rightarrow 5\sqrt{2}$ .

- Approximating  $\pi$  when the question asks for an exact answer.

Examiner  
only

17. Simplify

$$\frac{(5\sqrt{3})^2 - \frac{2\sqrt{18}}{\sqrt{2}}}{\sqrt{32} \times \sqrt{2}}$$

and state whether your answer is rational or irrational.

[5]

.....

.....

.....

.....

.....

.....

.....

.....

.....

.....

.....

.....

.....

.....

.....

.....

.....

.....

.....

.....

.....

.....



Examiner  
only

15. (a) Express  $0.\overline{37}$  as a fraction.

[2]

.....

.....

.....

.....

.....

.....

.....

.....

.....

.....

(b) (i) Calculate  $(\sqrt{8} - \sqrt{2})^2$ .

[2]

(ii) Calculate  $\frac{\sqrt{6} \times \sqrt{20}}{\sqrt{3}}$ .

Give your answer in the form  $a\sqrt{b}$ , where  $a$  and  $b$  are integers, and  $b$  is as small as possible.

[2]

.....

.....

.....

.....

.....



Examiner only

10. A tent company is designing a new 2-person tent.  
 The base of the tent is in the shape of a kite, as shown below.  
 The width of the kite is 160 cm, and the two shorter sides are of length 100 cm.  
 The point where the diagonals of the kite intersect has been marked  $O$  on the diagram below.

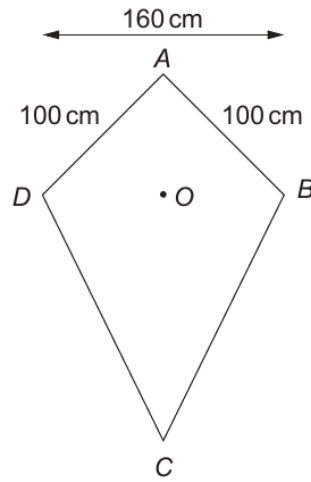

Diagram not drawn to scale

$E$  is the highest point of the tent, and is 110 cm vertically above  $O$ .  
 Part of the frame that supports the tent cover is a straight pole that goes from  $A$  to  $E$ .

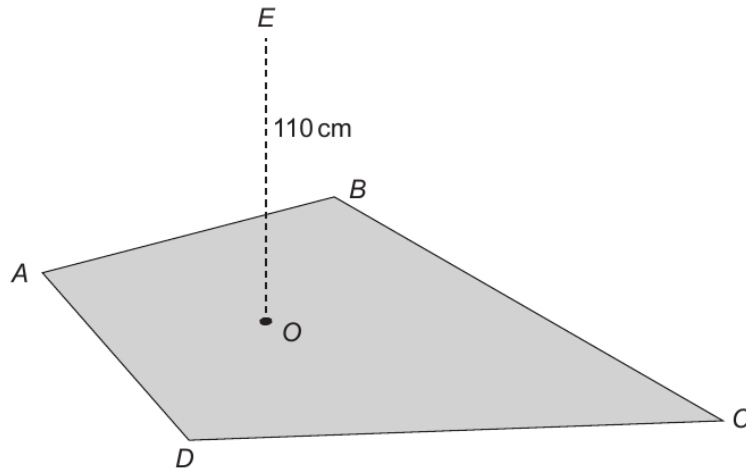

Diagram not drawn to scale

Calculate the length of pole  $AE$ .  
 Give your answer as a surd.  
 You do not need to simplify your answer.

[4]

.....

.....



11. (a) Alun is a jeweller.  
He is designing a symmetrical pendant, as shown below.

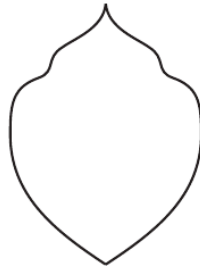
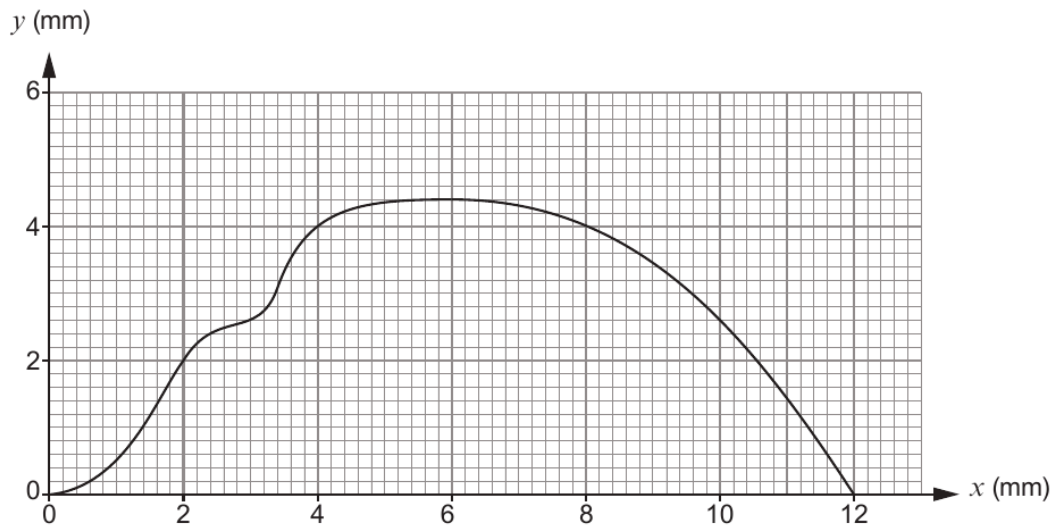
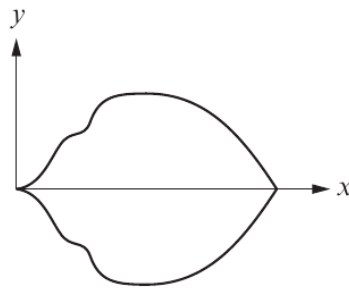

Diagram not drawn to scale

The pendant will be made from solid silver, with a uniform thickness of 3 mm.  
In order to calculate the cost of making the pendant, Alun wants to calculate an estimate of the volume of the pendant.

He has accurately drawn one of the symmetrical halves of the shape on graph paper.



Calculate an estimate of the volume of the whole pendant.  
Use the graph opposite, with 6 strips of equal width.

[5]

Examiner  
only

.....

.....

.....

.....

.....

.....

.....

.....

.....



.....

.....

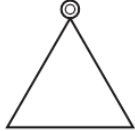

Examiner  
only

(b) Alun makes pendants that are mathematical shapes.  
The following table shows the pendants and the number of these pendants that Alun made last month.

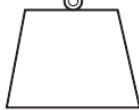
	Triangle	Circle	Rectangle	Trapezium
Pendant				
Number made last month	52	96	30	62

At the end of last month, Alun took a stratified sample of 30 of these 240 pendants to check their quality.

Calculate how many pendants of each shape were in Alun's sample.  
You must show all your working.

[4]

.....

.....

.....

.....

.....

.....

.....

.....

.....

.....

.....

.....

.....

.....

.....

.....

.....

Pendant	Triangle	Circle	Rectangle	Trapezium
Number in sample				



Examiner  
only

(c) Alun has 5 identical metal cylinders, each of length 40 mm.

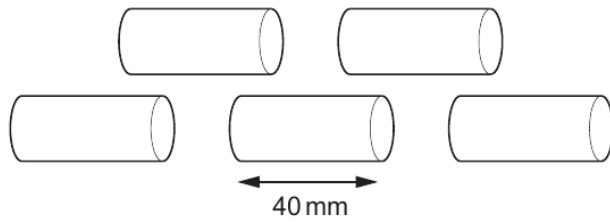

Diagram not drawn to scale

He has been asked to make a solid sphere of radius 30 mm.

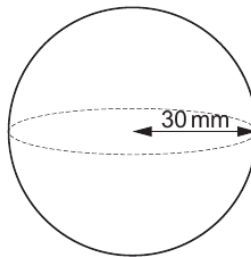

Diagram not drawn to scale

He melts the 5 cylinders and recasts all the metal to make the sphere.

Calculate the radius of each of the cylinders.

Give your answer in mm, in the form  $a\sqrt{b}$ , where  $a$  and  $b$  are integers, and  $b$  is as small as possible. [6]

.....

.....

.....

.....

.....

.....

.....

.....

.....

.....

.....







Examiner  
only

17. Evaluate the mean of the following three numbers:

$$\sqrt{20} \quad (\sqrt{5})^3 \quad 11\sqrt{5}$$

Express your answer in the form  $a\sqrt{5}$ , where  $a$  is an integer. [3]

.....

.....

.....

.....

.....

.....

.....

.....

.....

.....

.....

.....

.....

.....

.....

.....



Examiner  
only

9. Akago is a food delivery company.

(a) 5 Akago delivery vans can deliver food to 100 houses in 4 hours.

Akago wants to:

- increase the number of deliveries to 240 houses
- shorten the total delivery time to 3 hours.

Calculate the number of delivery vans that would be needed to deliver food to 240 houses in 3 hours.

You can assume that all vans deliver food to all the houses at the same rate.

[3]

.....

.....

.....

.....

.....

.....

.....

.....

.....

.....

.....

.....

.....

.....

.....

.....

.....

.....

.....

.....

.....

.....

.....

Number of delivery vans needed = .....



Examiner only

- (b) The design of the company's logo is based on the letter **A**. It is made from rectangles, connected by sectors of circles. The company prints its logo on its delivery boxes. The logo is shown below.

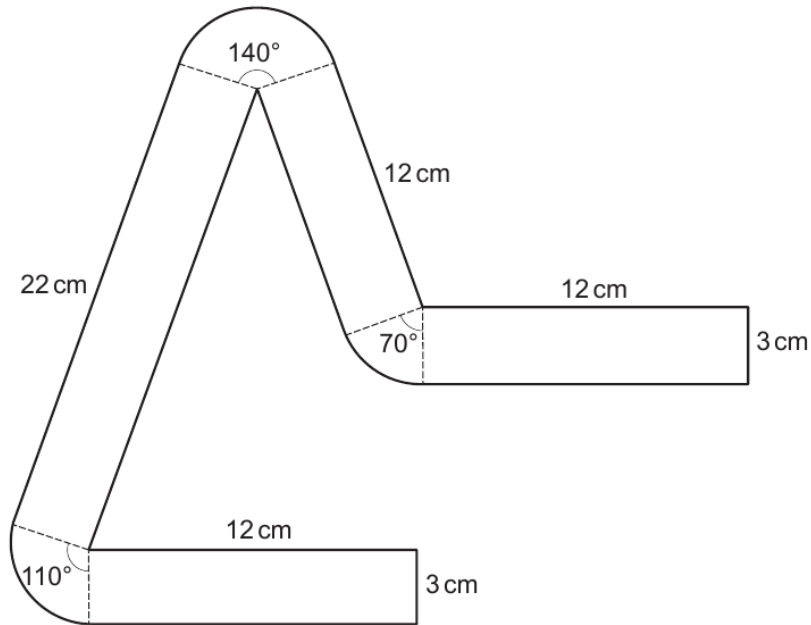

Diagram not drawn to scale

Calculate the area of the logo that is printed on the company's delivery boxes. Give your answer in terms of  $\pi$  in its simplest form.

[6]

.....

.....

.....

.....

.....

.....

.....

.....

.....

.....

.....

.....

.....

.....

.....

.....

.....

.....

.....

.....

.....

.....

.....



Examiner only

.....

.....

.....

.....

.....

Area of the logo = ..... cm<sup>2</sup>

- (c) Akago has decided to add two squares to its logo, to represent two stacked food boxes being delivered to your door.

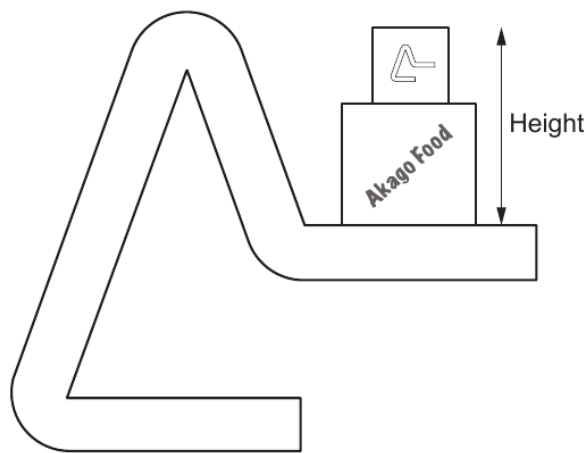

Diagram not drawn to scale

The larger square has an area of 45 cm<sup>2</sup>.  
 The smaller square has an area of 5 cm<sup>2</sup>.  
 Calculate the total height of the two stacked food boxes, as shown in the diagram.  
 Give your answer in the form  $a\sqrt{b}$ , where a and b are integers, and b is as small as possible. [3]

.....

.....

.....

.....

.....



Examiner  
only

15. In the following diagram:
- $CB$  and  $DE$  are parallel
  - $CE$  and  $BD$  are straight lines
  - $CA = AE$ .

Prove that triangles  $ABC$  and  $ADE$  are congruent.  
You must show all your working and explain your reasoning.

[2]

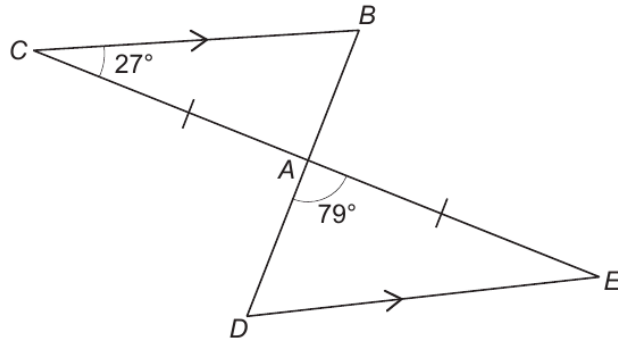

Diagram not drawn to scale

.....

.....

.....

.....

.....

.....

.....

.....

.....

.....

.....

.....

.....

.....

.....

.....

.....

.....

.....

.....

.....



Examiner only

10. Square-Off is a company that has designed new offices for its workers.

- (a) The main building has a square floor with an area of  $500\text{m}^2$ .  
 The reception has a square floor with an area of  $80\text{m}^2$ .  
 The triangular region outside the buildings is paved.  
 A plan view of the buildings and the paved region is shown below.

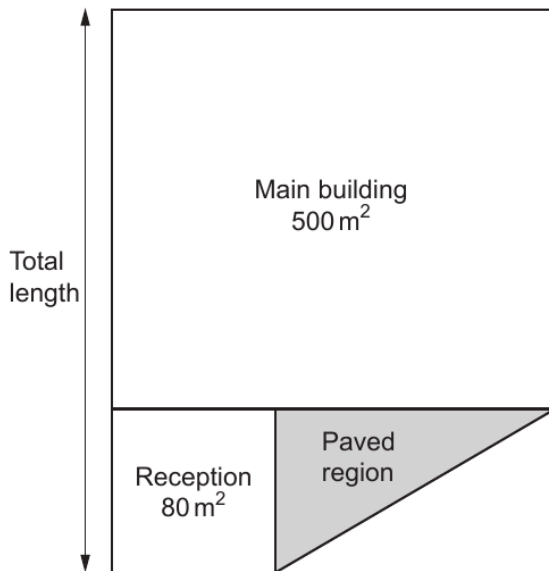

Diagram not drawn to scale

- (i) Calculate the total length of the two buildings.  
 Give your answer in the form  $a\sqrt{b}$ , where  $a$  and  $b$  are integers and  $b$  is a prime number. [3]

.....

.....

.....

.....

- (ii) Calculate the area of the paved region.  
 You must show all your working. [2]

.....

.....

.....

.....



(b) Square-Off has designed an entrance to the reception.

The symmetrical structure is made from 3 connected metal sheets, each in the shape of a trapezium.

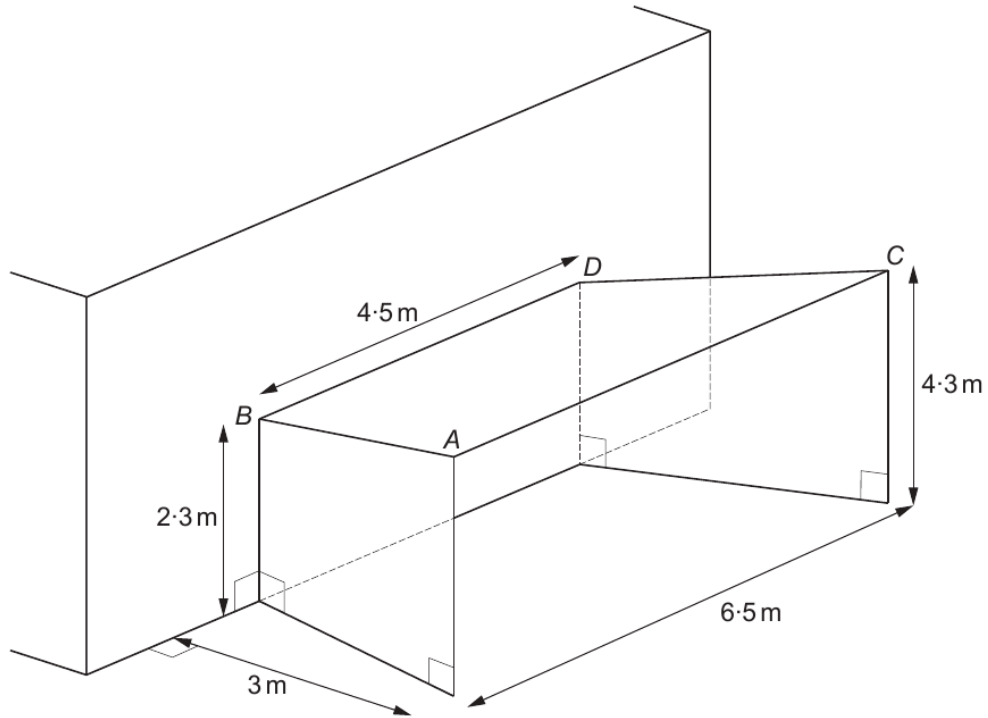

FRONT VIEW

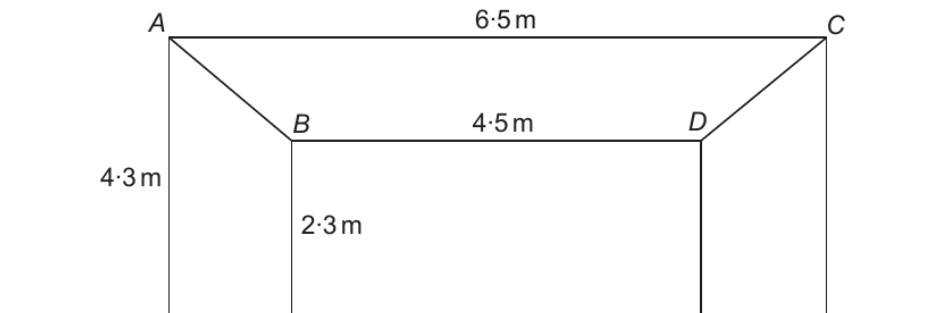

Diagrams not drawn to scale



Examiner  
only

The 3 metal sheets are connected to each other along the edges  $AB$  and  $CD$ .  
Adhesive strips are needed along the entire length of these edges.

Calculate the length of the adhesive strip  $AB$ .  
Leave your answer as a surd.

[4]

.....

.....

.....

.....

.....

.....

.....

.....

.....

.....

.....

.....

.....

.....

.....



Examiner only

12. The diagrams below show a solid cone and a circle.

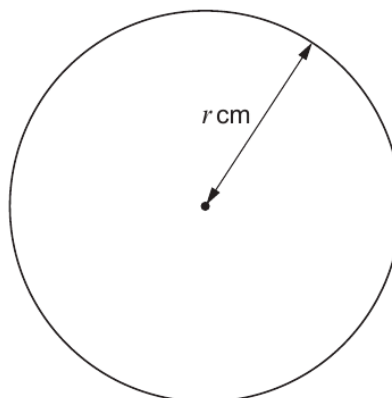
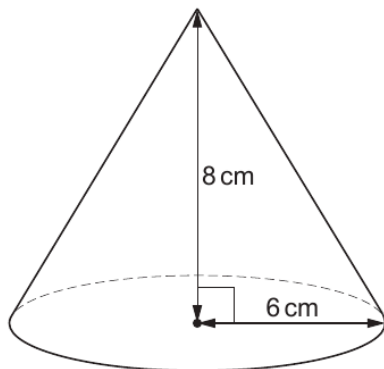

*Diagrams not drawn to scale*

The cone has a base radius of 6 cm and a vertical height of 8 cm.  
The circle has a radius of  $r$  cm.

The **curved** surface area of the cone equals the area of the circle.

By expressing any areas in terms of  $\pi$ , find the value of  $r$ .

Give your answer in the form  $a\sqrt{b}$ , where  $a$  and  $b$  are integers, and  $b$  is as small as possible.

[6]

.....  
.....  
.....  
.....  
.....  
.....  
.....  
.....  
.....  
.....  
.....  
.....  
.....  
.....  
.....  
.....  
.....  
.....  
.....  
.....  
.....  
.....

