

Name	Date started	Target end date

WJEC GCSE Mathematics and Numeracy (Double Award) – Question Pack

Foundation compound measures: speed, distance and time; density, mass and volume; flow rates. Confident unit handling and rearranging the formula triangle

REVISE

.wales

F3.07 – Compound measures – speed, density & flow rates

Spec 3.5.8, 3.5.9 – Unit 3 (calculator allowed)

Foundation compound measures: speed, distance and time; density, mass and volume; flow rates. Confident unit handling and rearranging the formula triangle are key. Sourced from legacy WJEC GCSE Mathematics-Numeracy Foundation papers (3300U10/U20) and accessible content from Intermediate papers (3300U30/U40), organised for revision under the 2025 spec.

2025 SPECIFICATION

Estimated time for entire question pack: ~56 minutes

Derived from the GCSE Higher pace of ~1.5 min/mark (37 marks across 12 questions).

You are advised to **not** attempt to complete all of this in one sitting.

ABOUT THIS QUESTION PACK

This is a **focused single-topic practice pack**, not a single mock paper. Questions are organised against the 2025 specification. Questions are ordered chronologically by sitting, with custom-written and SAM questions at the end.

INSTRUCTIONS

Use black ink or black ball-point pen. Show all working – method marks are awarded for clear setup.

A calculator is allowed on every question in this pack (Unit 3 is the calculator-allowed paper).

All question content is © WJEC CBAC Ltd. and reproduced for revision purposes only.

Compound measures – speed, density & flow rates – what the new spec asks

WJEC GCSE Mathematics (first teaching 2025) · Unit 3: calculator-allowed.

Speed 3.4.1

- Use speed = distance \div time.
- Rearrange for distance or time.
- Convert between m/s and km/h.

Density 3.4.2

- Use density = mass \div volume.
- Rearrange for mass or volume.
- Use consistent units (g/cm^3 or kg/m^3).

Flow rate 3.4.3

- Calculate flow rate from volume and time.
- Find time to fill a container.
- Use sensible units (l/min , cm^3/s).

Exam strategy 3.4

- Write the formula before substituting.
- Convert units first, then calculate.
- Always include units in the final answer.

Compound measures – speed, density & flow rates in one page

Quick-reference notes – revisit before each question. Don't use during the questions.

Speed

$$\text{speed} = \text{distance} \div \text{time}$$

Distance = speed \times time. Time = distance \div speed.

Units: mph, km/h, m/s.

Speed unit conversion

$$\text{m/s} \Rightarrow \text{km/h}: \times 3.6.$$

$$\text{km/h} \Rightarrow \text{m/s}: \div 3.6.$$

Always match units before calculating.

Density

$$\text{density} = \text{mass} \div \text{volume}$$

Units: g/cm^3 or kg/m^3 .

Water has density 1 g/cm^3 .

Flow rate

$$\text{flow rate} = \text{volume} \div \text{time}$$

Units: litres/min, cm^3/s .

Time to fill = volume \div flow rate.

Time conversions

$$1 \text{ h} = 60 \text{ min} = 3\,600 \text{ s}.$$

$$2 \text{ h } 30 \text{ min} = 2.5 \text{ h. Not } 2.30 \text{ h}.$$

Common traps

- Using 2.30 h for 2 h 30 min.
- Mixing m and km, or kg and g.
- Forgetting units in the final answer.

15. Solve the following simultaneous equations using an algebraic (not graphical) method.

$$\begin{aligned} 5x + 3y &= 11 \\ 2x - 7y &= 29 \end{aligned}$$

You must show all your working.

[4]

Examiner
only



Examiner
only

16. A solid object is made by drilling a cylindrical hole of radius 4 cm through a cuboid measuring 20 cm by 15 cm by 10 cm as shown below.

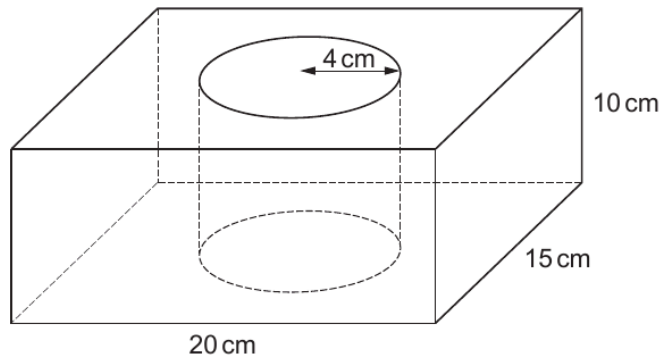

Diagram not drawn to scale

- (a) Calculate the volume of the object.
Give your answer in cm^3 .

[3]

.....

.....

.....

.....

.....

.....

.....

Volume = cm^3



9. (a) Express 54 miles as a percentage of 300 miles. [2]

.....

.....

.....

.....

(b) A car travels 100 miles in 2 hours and 30 minutes. Calculate its average speed in miles per hour. [3]

.....

.....

.....

.....

.....

Examiner
only



Examiner
only

8. (a) The population of Barbados in 1644 was said to be 30 000.
By 1964, the population of Barbados had increased by 682%.
From 1964 to 2014, the population of Barbados increased by a further 20%.



Calculate the population of Barbados in 2014.
You must show all your working.

[3]

.....

.....

.....

.....

.....

.....

- (b) The area of Barbados is 432 km^2 .
The population of Barbados in September 2019 was 287 106.

Calculate the population density of Barbados in September 2019.
Give your answer correct to 2 significant figures.

[3]

.....

.....

.....

.....

.....

- (c) The density of some of the sand in Barbados is 1442 kg/m^3 .
Express this density in g/cm^3 .

[2]

.....

.....

.....

END OF PAPER



Examiner
only

6. A journey of 45 miles is travelled in 1 hour 15 minutes.
Calculate the average speed of this journey.
Give your answer in mph.

[3]

.....

.....

.....

.....

.....

.....

7. A regular polygon has 15 sides.
Calculate the size of an exterior angle of this regular polygon.

[2]

.....

.....

.....

.....

.....

.....



Examiner
only

12. The diagram below shows the positions of three points *A*, *B* and *C* on a map.
The diagram is drawn to scale.

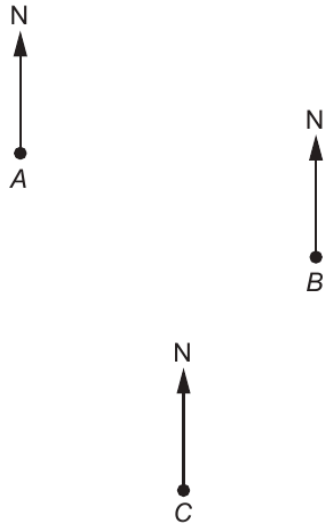

(a) Find the bearing of *B* from *A*. [1]

.....

.....

.....

.....

(b) Find the bearing of *A* from *C*. [1]

.....

.....

.....

.....



Examiner only

14.

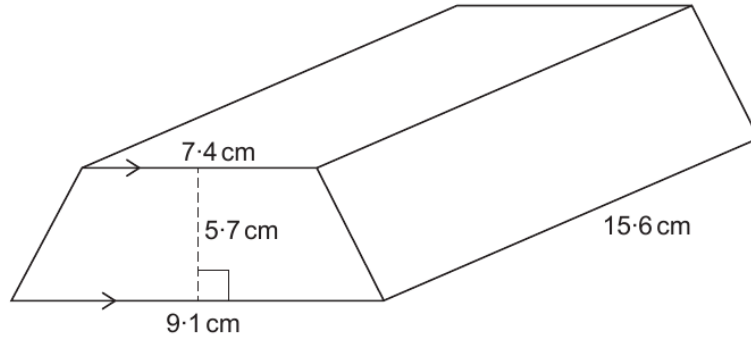

Diagram not drawn to scale

(a) Find the volume of the solid prism shown above. [3]

.....

.....

.....

.....

.....

.....

(b) The solid prism is made of gold.
Gold has a density of 19.3 g/cm^3 .
Calculate the mass of the prism.
Give your answer in **kilograms**. [3]

.....

.....

.....

.....

.....

.....

.....

.....

.....

.....

Mass of the prism = kg



Examiner
only

2. Idris flies from Cardiff to Faro, in Portugal.

(a) The actual flying time is 133 minutes.
The plane flies at an average speed of 8 miles per minute.

(i) Calculate the flying distance between Cardiff and Faro.
Give your answer in miles. [2]

.....

.....

.....

.....

(ii) Calculate the plane's average speed in **miles per hour**. [2]

.....

.....

.....

(b) Idris takes a cabin bag on board his flight.
His bag measures 55 cm by 40 cm by 23 cm.
The label on his cabin bag says,

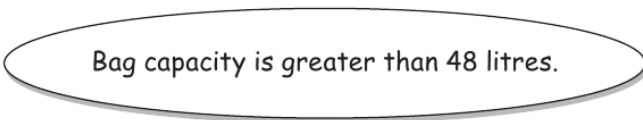

Is this label correct?

Yes No

You must show all your working and give a reason for your answer. [3]

.....

.....

.....

.....

.....



Examiner only

- (c) Idris looks out of the aeroplane window. He notices a village below. Idris takes a photograph of the village to try to work out where he is. From the photograph, he draws a sketch including some parallel streets. His sketch is shown below.

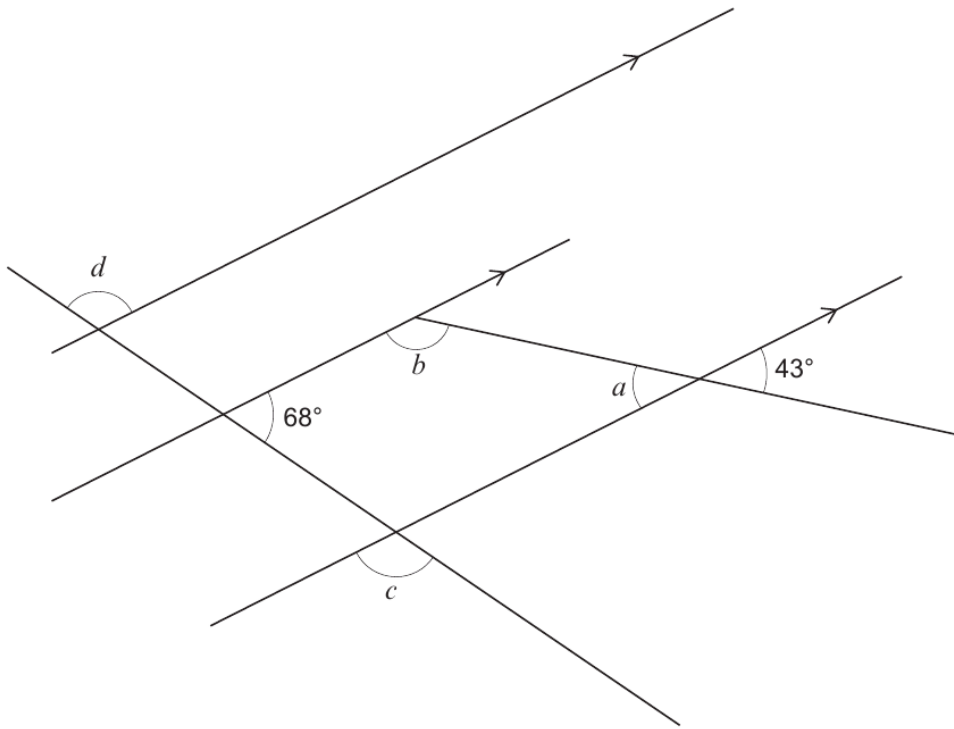

Diagram not drawn to scale

Find the size of each of the angles a , b , c and d .

[4]

.....

.....

$a = \dots\dots\dots^\circ$ $b = \dots\dots\dots^\circ$ $c = \dots\dots\dots^\circ$ $d = \dots\dots\dots^\circ$

3310U401
05



Examiner only

9. (a) The area of Wales is $20\,735\text{km}^2$.

The table below gives the population of Wales in 1977, 1998 and 2015.



Year	1977	1998	2015
Population	2.8 million	2.9 million	3.1 million

(i) What was the increase in the population of Wales between 1977 and 1998?
Circle your answer.

[1]

- 1×10^3
- 1×10^4
- 1×10^5
- 1×10^6
- 1×10^7

.....
.....

(ii) Estimate the population density of Wales in 2015.

[3]

.....
.....
.....
.....
.....
.....

Population density of Wales in 2015 was people/ km^2

(b) Cardiff is the largest city in Wales.
In 2018, the population of Cardiff was approximately 360 000.
The population of Cardiff increased by 20% from 1991 to 2018.
Calculate the population of Cardiff in 1991.

[3]

.....
.....
.....
.....
.....



Examiner only

(c) DraigYma prints Welsh flags onto stickers. Three of their mathematically similar Welsh flag stickers are shown below.

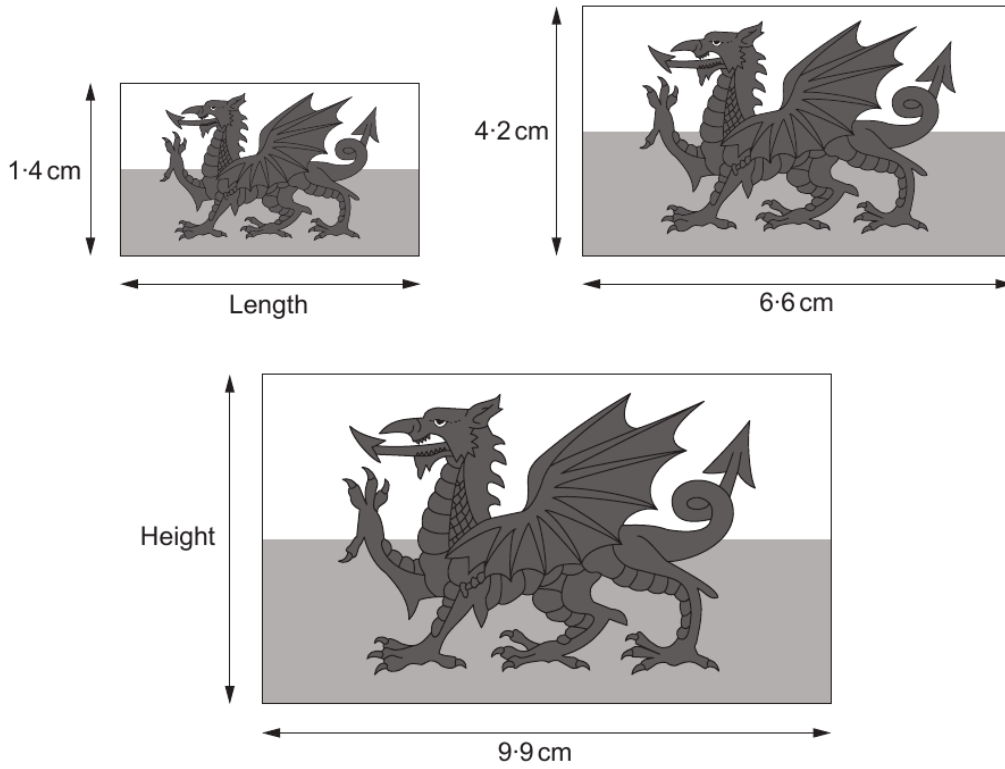

Diagrams not drawn to scale

Calculate the missing length and height in the diagrams.

[4]

.....

.....

.....

.....

.....

.....

.....

Length is cm Height is cm

END OF PAPER



Examiner
only

16. (a) Express 0.0057 in standard form. [1]

.....

(b) Calculate the value of $\frac{2 \times 10^4}{5 \times 10^{-3}}$.
Give your answer in standard form. [2]

.....

.....

.....

17. A car travels a distance of x miles in 2 hours.
In the next hour, it travels a further distance of 36 miles.

Its average speed for the whole journey is 42 mph.

Calculate the value of x .
You must show all your working. [3]

.....

.....

.....

.....

.....

.....

.....

.....

.....

.....

.....

.....



Examiner
only

8. (a) A small packet contains four Caru chocolate cakes.

The four cakes have a total mass of 84 g.



(i) The following information is written on the packet:

'Caru chocolate cakes contain 600 calories per 100g.'

Simon aims for a calorie intake of 2400 calories per day.

Today Simon eats **one** Caru chocolate cake.

What percentage of his daily calorie intake is this cake?

You must show all your working.

[5]

.....

.....

.....

.....

.....

.....

.....

.....

.....

.....

(ii) Caru chocolate cakes contain only fat, carbohydrate, protein and salt.

The ratio of the masses is

fat : carbohydrate : protein : salt = 1360 : 2725 : 515 : 4

How many grams of protein are there in an 84 g packet of four cakes?

Give your answer correct to 2 significant figures.

[3]

.....

.....

.....

.....

.....



Examiner only

9. (a) The base of a flagpole is fixed to horizontal ground. It is held vertically by a straight rod of length 3.8 m. The rod is fixed to the ground and to a point 1.5 m from the top of the flagpole. The flagpole and the rod are shown in the diagram below.

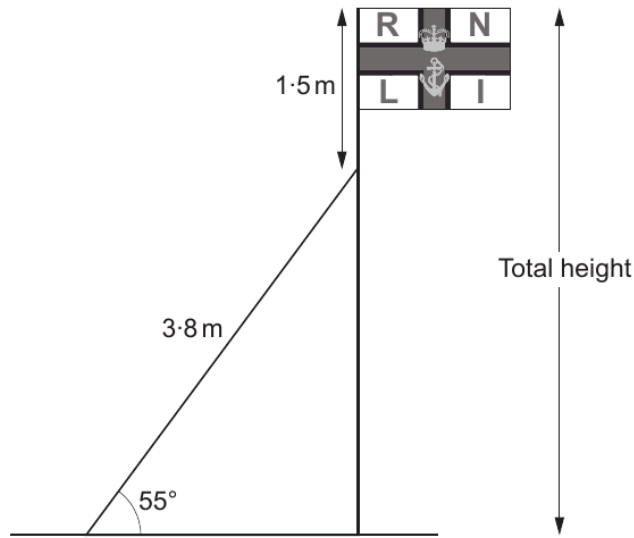

Diagram not drawn to scale

Calculate the **total** height of the flagpole.
Give your answer correct to the nearest centimetre.

[4]

.....

.....

.....

.....

.....

.....

.....



Examiner
only

(b) Mathematically similar large, medium and small flags are made.

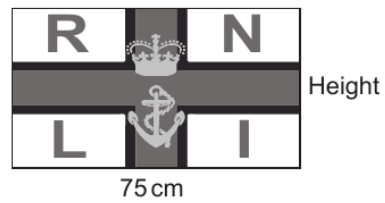
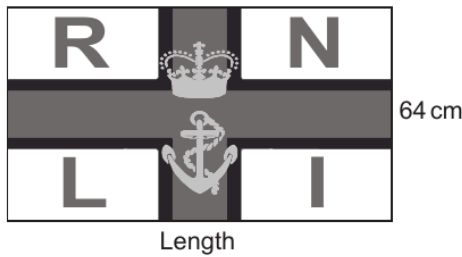
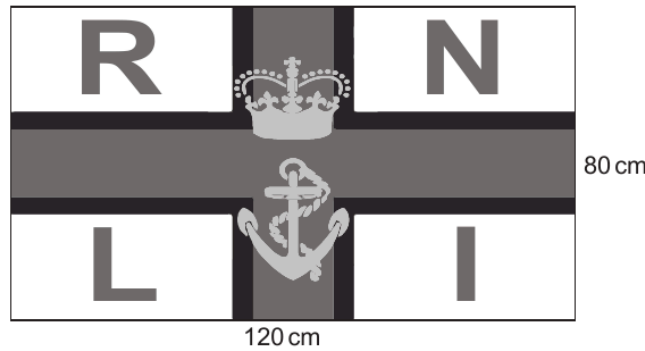

Diagrams not drawn to scale

(i) Calculate the length of the medium flag. [2]

.....
.....
.....
.....

Length of the medium flag is cm

(ii) Calculate the height of the small flag. [2]

.....
.....
.....
.....

Height of the small flag is cm

