

Name	Date started	Target end date

WJEC GCSE Mathematics and Numeracy (Double Award) – Question Pack

Foundation coordinate geometry and transformations: reading and plotting coordinates, finding midpoints by averaging, identifying lines of symmetry, a

REVISE
.wales

F2.17 – Coordinates from geometry; symmetry & transformations

Spec 3.8.1, 3.8.2, 3.8.3, 3.8.4, 3.8.5, 3.8.6 – Unit 2 (no calculator)

Foundation coordinate geometry and transformations: reading and plotting coordinates, finding midpoints by averaging, identifying lines of symmetry, and describing the four single transformations – reflection in a mirror line, rotation about a centre, translation by a column vector, and enlargement by a scale factor. Sourced from legacy WJEC GCSE Mathematics-Numeracy Foundation papers (3300U10/U20) and accessible content from Intermediate papers (3300U30/U40), organised for revision under the 2025 spec.

2025 SPECIFICATION

Estimated time for entire question pack: ~2 hours 30 minutes

Derived from the GCSE Higher pace of ~1.5 min/mark (100 marks across 39 questions).

*You are advised to **not** attempt to complete all of this in one sitting.*

ABOUT THIS QUESTION PACK

This is a **focused single-topic practice pack**, not a single mock paper. Questions are organised against the 2025 specification. Questions are ordered chronologically by sitting, with custom-written and SAM questions at the end.

INSTRUCTIONS

Use black ink or black ball-point pen. Show all working – method marks are awarded for clear setup.

*A calculator is **not** permitted on any question in this pack (Unit 2 is the non-calculator paper).*

All question content is © WJEC CBAC Ltd. and reproduced for revision purposes only.

Coordinates from geometry; symmetry & transformations – what the new spec asks

WJEC GCSE Mathematics (first teaching 2025) · Unit 2: non-calculator.

Coordinates 3.8.1

- Read and plot points in all four quadrants.
- Find the midpoint of a line segment by averaging coordinates.

Symmetry 3.8.2

- Identify lines of symmetry on a 2-D shape.
- State the order of rotational symmetry.

Reflection and rotation 3.8.3

- Reflect a shape in a given mirror line.
- Rotate a shape by 90° or 180° about a given centre.
- Fully describe a reflection or rotation.

Translation 3.8.4

- Translate a shape using a column vector.
- Describe a translation as a column vector.

Coordinates from geometry; symmetry & transformations in one page

Quick-reference notes – revisit before each question. Don't use during the questions.

Coordinates and midpoint

Point (x, y) : along then up.

Midpoint of (x_1, y_1) and (x_2, y_2) =

$((x_1+x_2)/2, (y_1+y_2)/2)$ – average the coordinates.

Symmetry

Line symmetry: fold along the mirror line, the halves match.

Rotational symmetry: order = number of times the shape looks the same in a full turn.

Reflection

To **describe:** give the equation of the mirror line (e.g. $x = 2$, $y = -1$, $y = x$).

Rotation

To **describe:** angle, direction (clockwise / anticlockwise) and centre.

Common: 90° or 180° about the origin.

Translation

Described by a **column vector** (a / b) – a right, b up.

Negative entries mean left or down.

Common traps

- Swapping x and y when plotting.
- Forgetting the centre when describing a rotation.
- Stating direction only (left/right) instead of a column vector for a translation.

3. Shade the smallest number of squares needed to make the line AB a line of symmetry. [2]

Examiner
only

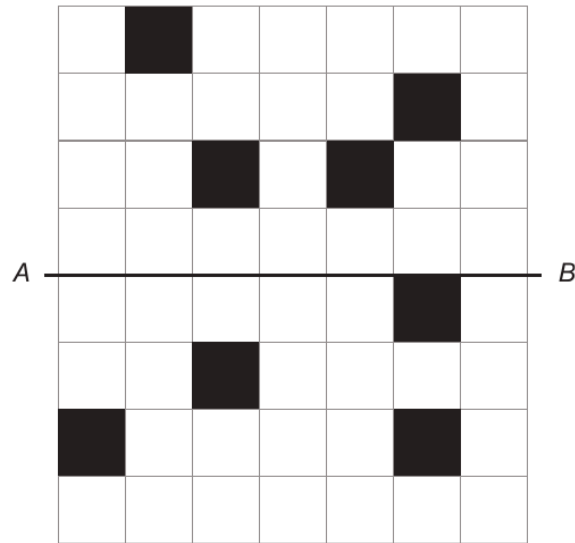

3300U101
05



Examiner
only

3. (a) Reflect the triangle below in the x -axis.

[1]

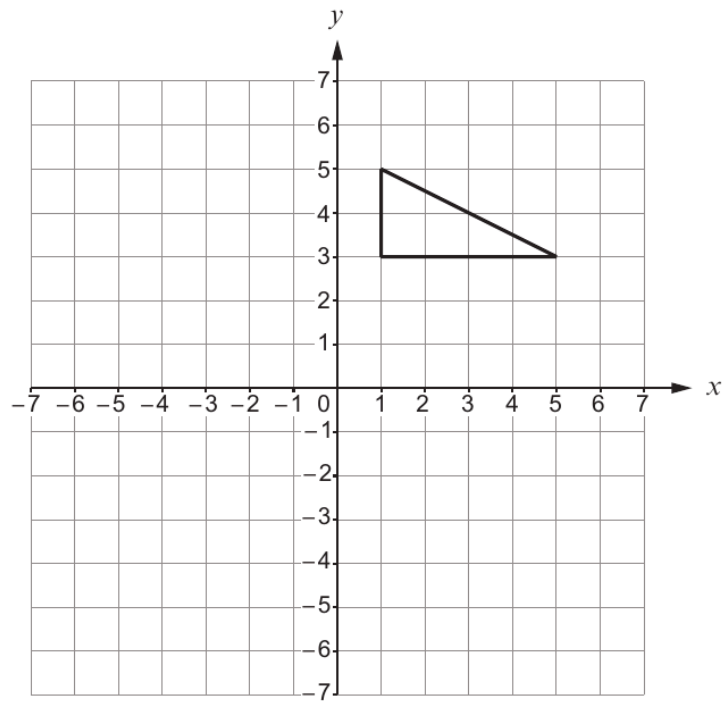

- (b) Enlarge the triangle below by a scale factor of 3.

[2]

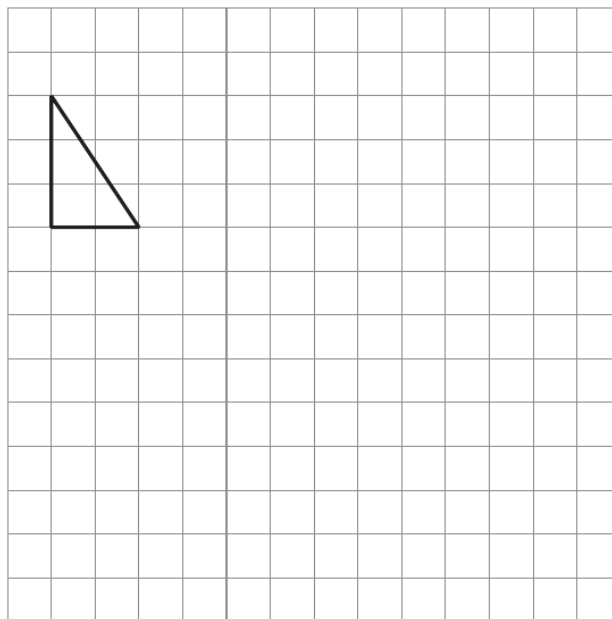

(c) Translate the triangle below 3 squares to the left and 2 squares down.

[1]

Examiner
only

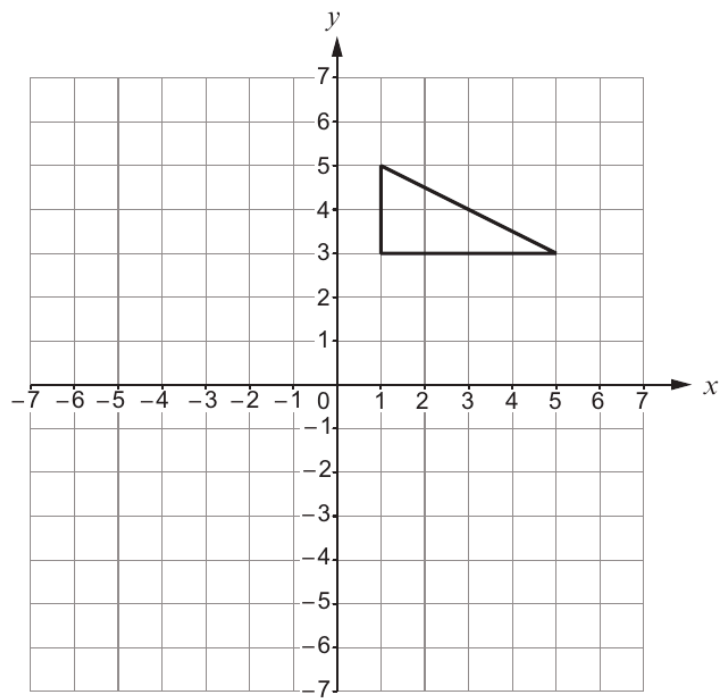

Examiner
only

4. Matthew writes down three **different** numbers.
- One number is a square number.
 - The other two numbers are factors of 20.
 - The sum of the three numbers is 24.

What three numbers did Matthew write down? [3]

.....

.....

.....

.....

.....

.....

Matthew's three numbers are, and

5. (a) What is the order of rotational symmetry of the shape below? [1]

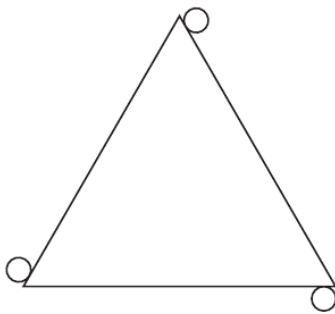

.....

- (b) Name a 4-sided shape with rotational symmetry of order 4. [1]

.....

.....

3300U201
05



Examiner only

2. (a) The square drawn below has rotational symmetry of order 4.
Place **two** identical dots (●) on the square so that it will have rotational symmetry of order 2. [1]

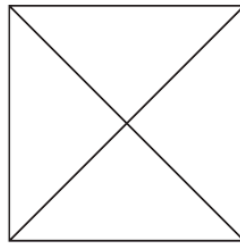

- (b) The regular hexagon drawn below has rotational symmetry of order 6.
Place **three** identical dots (●) on the regular hexagon so that it will have rotational symmetry of order 3. [1]

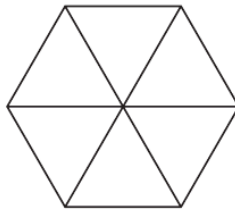

- (c) Which of the following shapes has rotational symmetry of order 3, but has **no** line symmetry?
Circle the correct shape. [1]

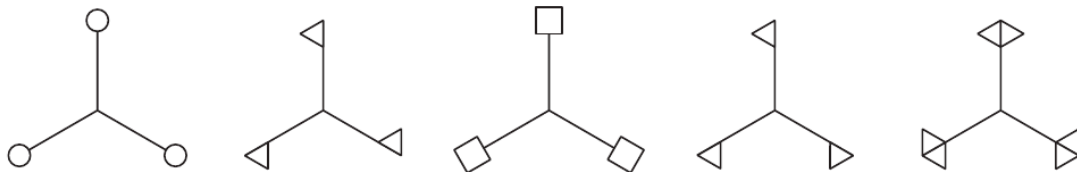

3300U401
05



Examiner
only

2. (a) Mai has a box of 60 different beads.
There are 40 red beads in the box.
Mai chooses a bead at random from the box.

Describe the chance that Mai chooses a red bead.
Circle the correct expression from those given below.

[1]

impossible **unlikely** **an even chance** **likely** **certain**

- (b) Ifan has a box of 12 cakes.
There are 6 chocolate cakes and the rest are lemon cakes.
Ifan chooses a cake at random from the box.

Describe the chance that Ifan chooses a lemon cake.
Circle the correct expression from those given below.

[1]

impossible **unlikely** **an even chance** **likely** **certain**

3. Draw all the lines of symmetry on the following shapes.

[2]

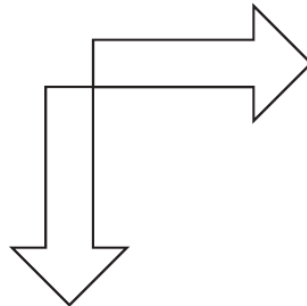
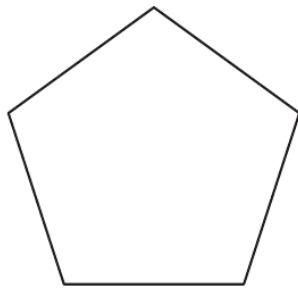
3300U101
05

Examiner
only

11. Rhys wrote down four whole numbers.

The mode of the four numbers is 7.
The median of the four numbers is 6.
The range of the four numbers is 5.

What are the four numbers that Rhys wrote down?
You must show all your working.

[3]

.....

.....

.....

.....

.....

.....

.....

.....

.....

.....

.....

.....

.....

.....

.....

.....

.....

.....

.....

.....

.....

.....

Rhys's numbers are , , and

3300U201
09



18. (a) Reflect the shape S in the line $y = 1$.

[2]

Examiner
only

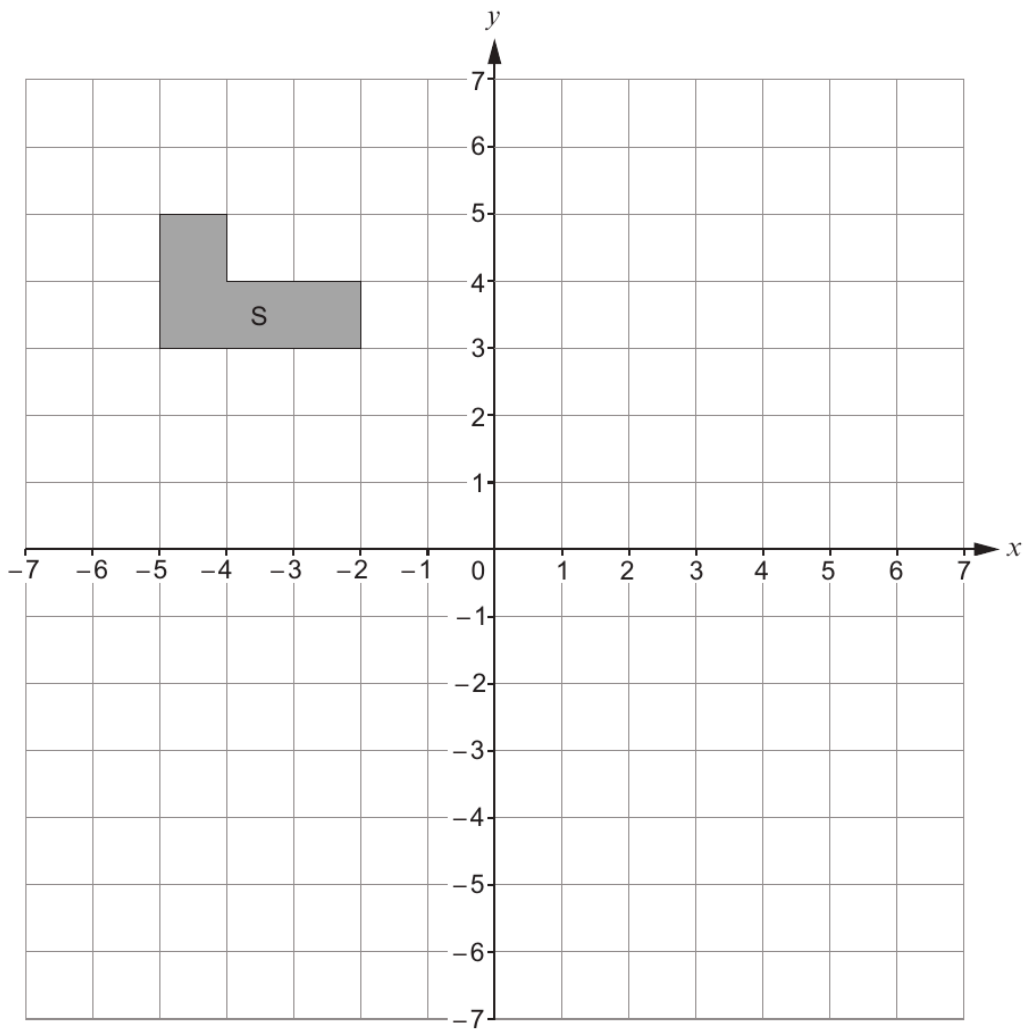

(b) Describe **fully** the **single** transformation that transforms shape S to shape T. [3]

Examiner
only

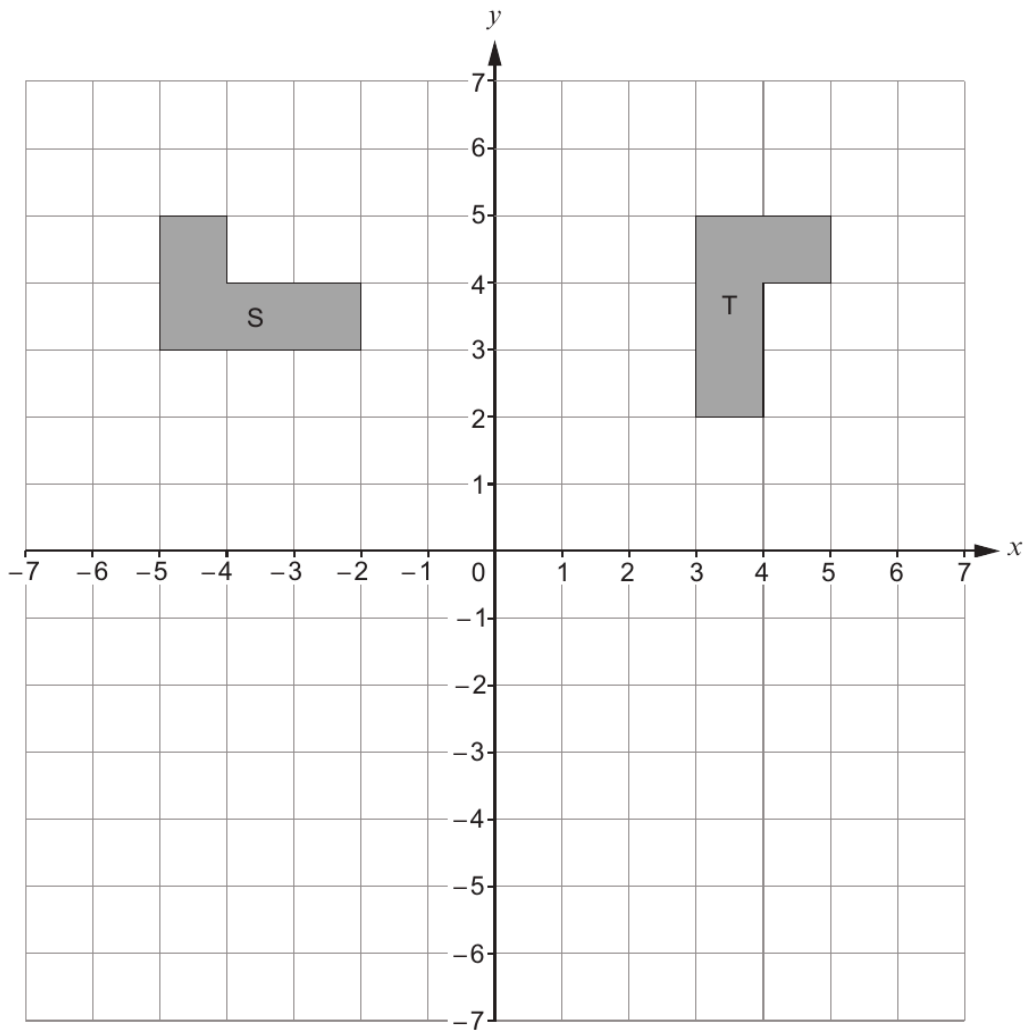

.....

.....

.....

END OF PAPER



Examiner only

5. (a) Complete the following figure so that it is symmetrical about the line AB. [2]

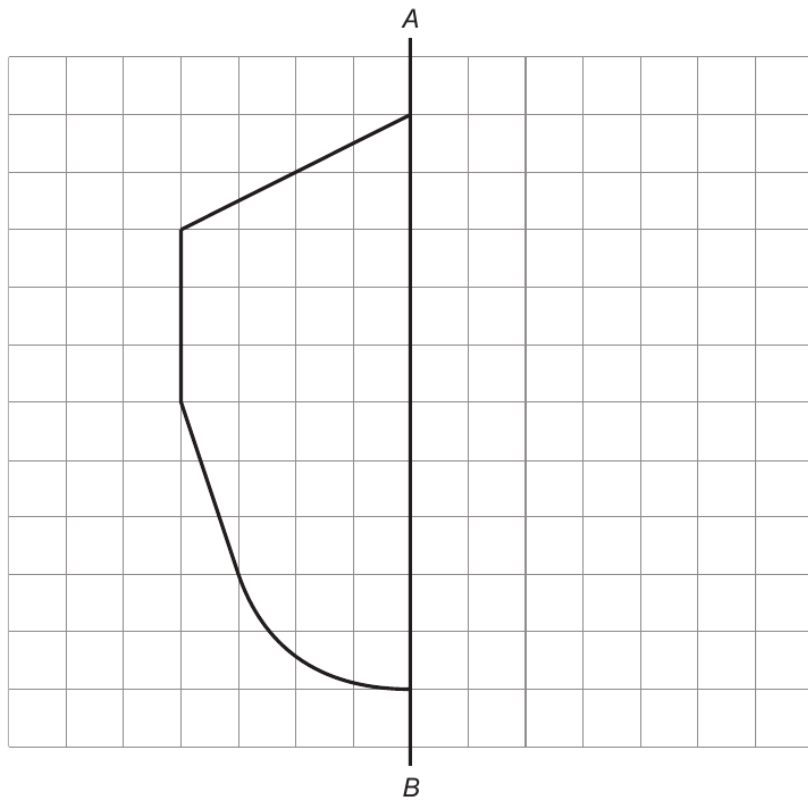

- (b) Ben draws a shape that has:
- 4 sides,
 - 4 angles of equal size,
 - a pair of sides of length 4 cm, and
 - a pair of sides of length 6 cm.

What type of shape has Ben drawn?
Circle the correct answer.

square rhombus trapezium rectangle kite

(c) Write down the special name for the shape below. [1]

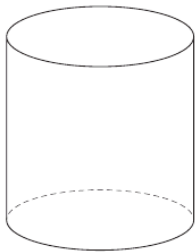

.....



Examiner only

8.

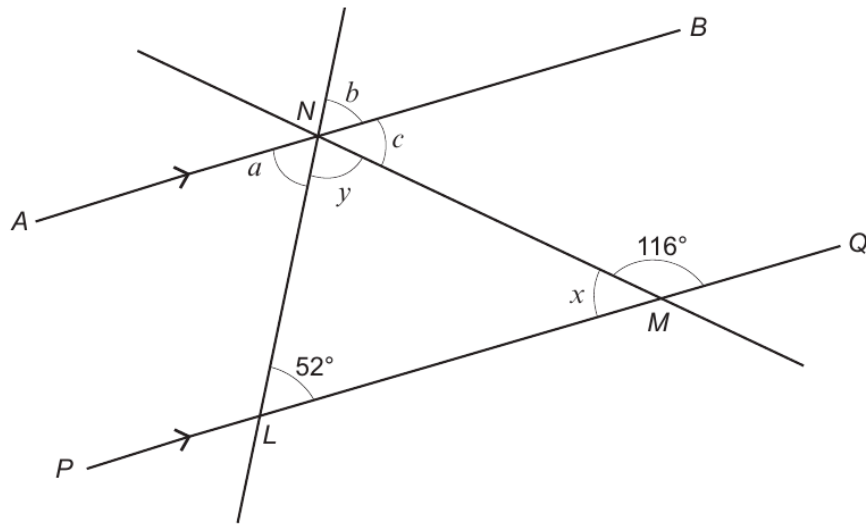

Diagram not drawn to scale

Line AB is parallel to line PQ .

(a) Find the size of each of the angles a , b and c .

[3]

.....

.....

.....

.....

.....

$a = \dots\dots\dots^\circ$ $b = \dots\dots\dots^\circ$ $c = \dots\dots\dots^\circ$



(b) Find the size of each of the angles x and y .
Hence give the special name for triangle LMN .

[3]

Examiner
only

.....

.....

.....

.....

$$x = \text{.....}^\circ \quad y = \text{.....}^\circ$$

The special name for triangle LMN is



Examiner only

12. Place the numbers 1, 2, 3, 4, 5 in the Venn diagram below. [2]

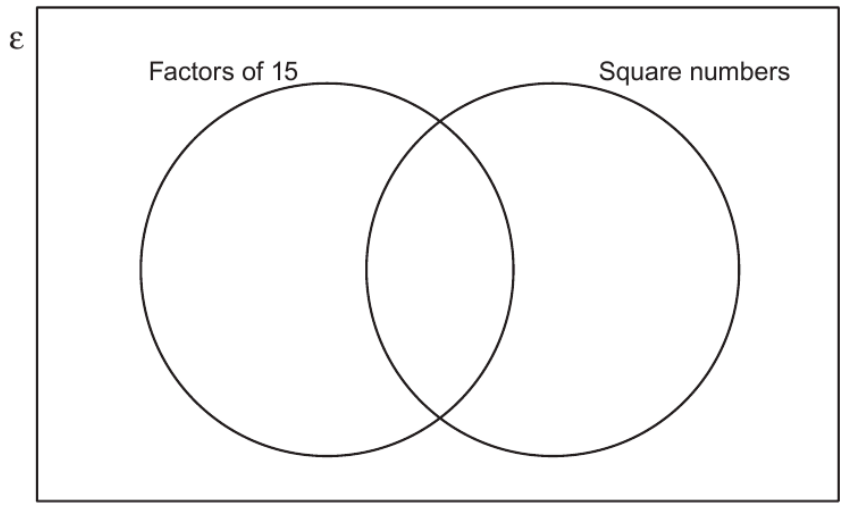

Space for working:

.....

.....

.....

13. Write down the order of rotational symmetry for each of the following. [2]

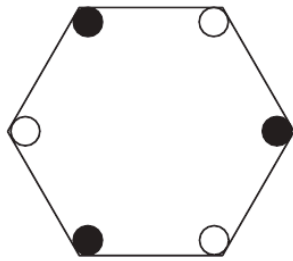

.....

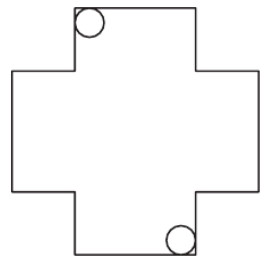

.....



Examiner
only

2. (a) *In this part of the question, you will be assessed on the quality of your linguistic and mathematical accuracy in writing.*

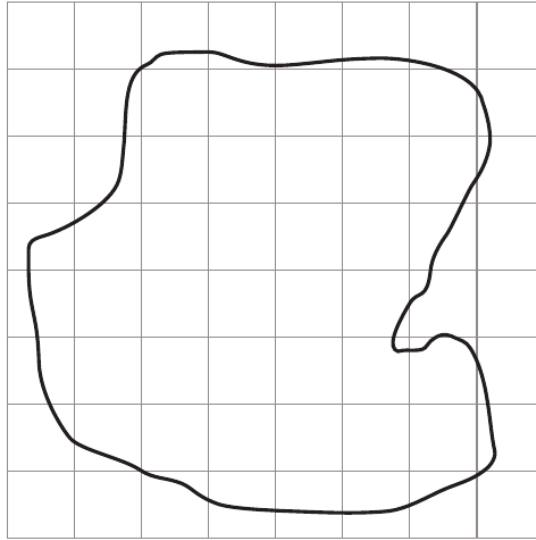

The shape above has been drawn on a square grid.
Each square represents an area of 5 cm^2 .
Estimate the total area of the shape.
You must show all your working.

[3 + 1 W]

.....

.....

.....

.....

.....



Examiner
only

3. (a) Shade **one square** so that the diagram below has rotational symmetry of order 2. [1]

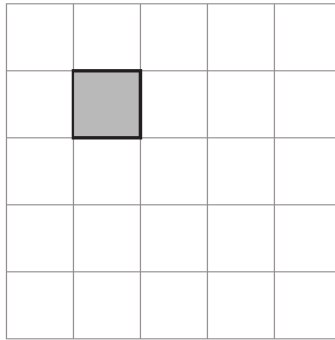

- (b) Shade **two squares** so that the diagram below has rotational symmetry of order 4. [1]

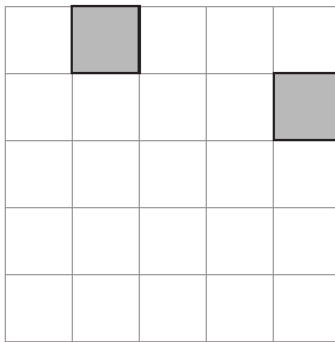

- (c) Shade **two squares** so that the diagram below has rotational symmetry of order 3. [1]

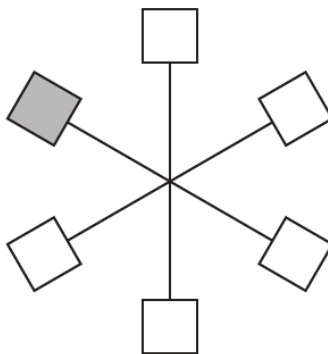

3300U301
05



Examiner
only

7. Circle the correct answer for each question below.

(a) What is the special name of the shape below? [1]

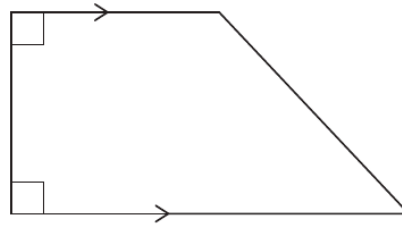

pentagon rhombus trapezium rectangle kite

(b) What is the special name of the 3D shape below? [1]

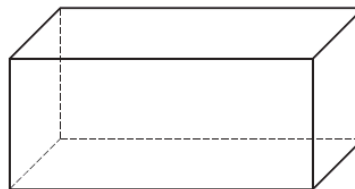

cube cuboid cylinder cone sphere

(c) What type of angle is an angle of 181° ? [1]

an acute angle an obtuse angle a straight line a right angle a reflex angle

(d) Which shape has rotational symmetry of order 2? [1]

parallelogram square equilateral triangle isosceles triangle scalene triangle

3300U201
07

Examiner
only

11. 200 young people are taking part in a conference held at Aberystwyth.

(a) One of the young people is chosen at random to be the chairperson.

Complete the table below to find the probability that the person chosen lives outside the United Kingdom (UK). [2]

	North Wales	Mid Wales	South Wales	Elsewhere in the UK	Outside the UK
Probability	0.2	0.3	0.25	0.15	

.....

.....

.....

.....

(b) How many of the 200 young people live in Mid Wales? [2]

.....

.....

.....

.....

.....

.....

.....

.....

3300U301
11



1. Fill in the boxes below to make each calculation correct.

[4]

Examiner
only

$$\boxed{\text{£}1.63} + \boxed{35\text{p}} = \boxed{\text{£} \dots\dots\dots}$$

$$\boxed{\text{£}1.73} + \boxed{\dots\dots\dots \text{p}} = \boxed{\text{£}2.26}$$

$$\boxed{7} \times \boxed{84\text{p}} = \boxed{\text{£} \dots\dots\dots}$$

$$\boxed{17} \times \boxed{\text{£} \dots\dots\dots} = \boxed{\text{£}6.97}$$

Space for working:

.....

.....

.....

.....

.....



Examiner only

4. (a) One of these letters has exactly one line of symmetry.
Circle this letter.

[1]

P H Z D O

- (b) One of these letters has rotational symmetry of order 2.
Circle this letter.

[1]

V T S L M

5. (a) Write a number in the empty box to make the calculation correct.

[1]

$$20 - \boxed{} + 6 = 17$$

.....
.....

- (b) Put +, −, × or ÷ in each space below to make the calculation correct.

[1]

$$18 \dots\dots\dots 6 \dots\dots\dots 2 = 1$$

.....
.....

3300U101
05



Examiner
only

5. (a) Shade the least number of squares so that the grid has rotational symmetry of order 2. The squares you shade must be in the upper two quadrants. [2]

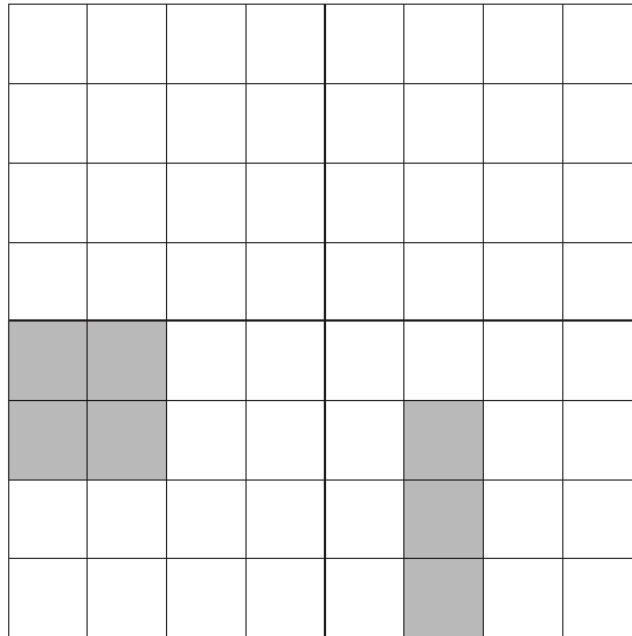

(b) Describe fully the **single** transformation that transforms shape A onto shape B. [2]

Examiner only

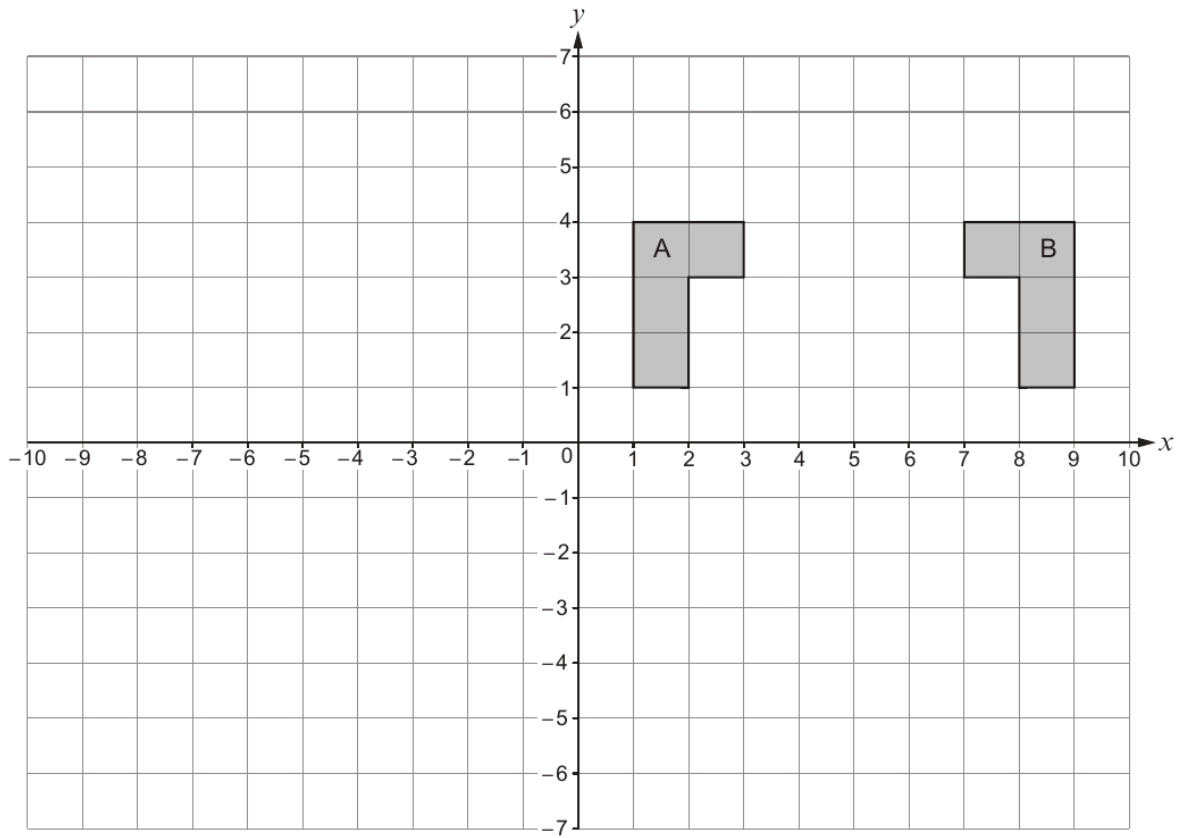

3300U401
07

.....

.....

.....

.....



Examiner only

11. (a) Write down the next two numbers in the following sequence. [2]

50 39 28 17

.....
.....

(b) Use the formula $x = 4a + 3b$ to find the value of x when $a = 7.2$ and $b = -4.6$. [2]

.....
.....
.....

12. Identical rods can be placed end to end, as shown below.
Each rod is 17.5 cm long.

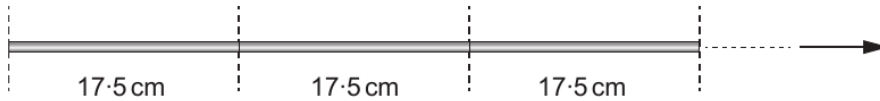

How many of these rods can be placed, in this way, between two points 4 metres apart? [4]

.....
.....
.....
.....
.....
.....
.....
.....

Number of rods =



Examiner only

2. (a) Tim chooses one letter at random from the word TOMATO.

Describe the chance that Tim chooses the letter T.
Circle the correct expression from those given below.

[1]

impossible unlikely an even chance likely certain

- (b) Megan chooses one letter at random from the word BANANA.

Describe the chance that Megan chooses the letter A.
Circle the correct expression from those given below.

[1]

impossible unlikely an even chance likely certain

3. Shade the smallest number of squares to make MN a line of symmetry. [1]

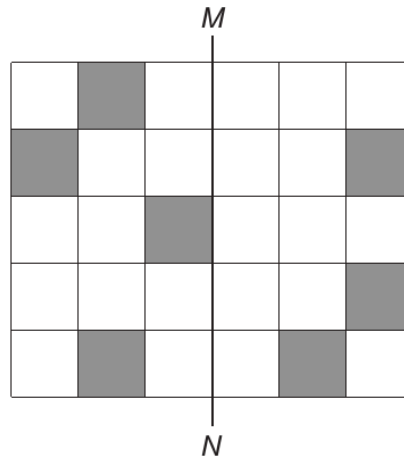

Examiner only

9. Complete the diagram so that the grid has rotational symmetry of order 4 about the centre, ● . You must shade as few squares as possible. [2]

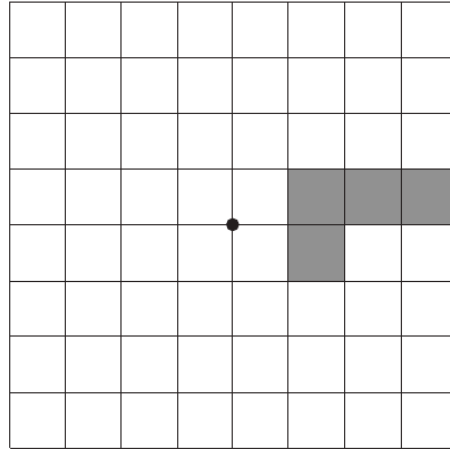

10. In this question, you will be assessed on the quality of your organisation and communication.

A bucket can hold 4000 ml of water.
A jug can hold 2.5 litres of water.
An empty tank has a capacity of 17 litres.

The tank is filled to the top using a combination of full buckets and full jugs of water.
How many full buckets and full jugs must be used to fill the tank exactly?
You must show all your working.

[4 + 1 OC]

.....

.....

.....

.....

.....

.....

.....

.....

.....

.....

.....

Number of full buckets

Number of full jugs

3300U101
09



1. (a) Enlarge the shape below by a scale factor of 3.

Examiner only
[2]

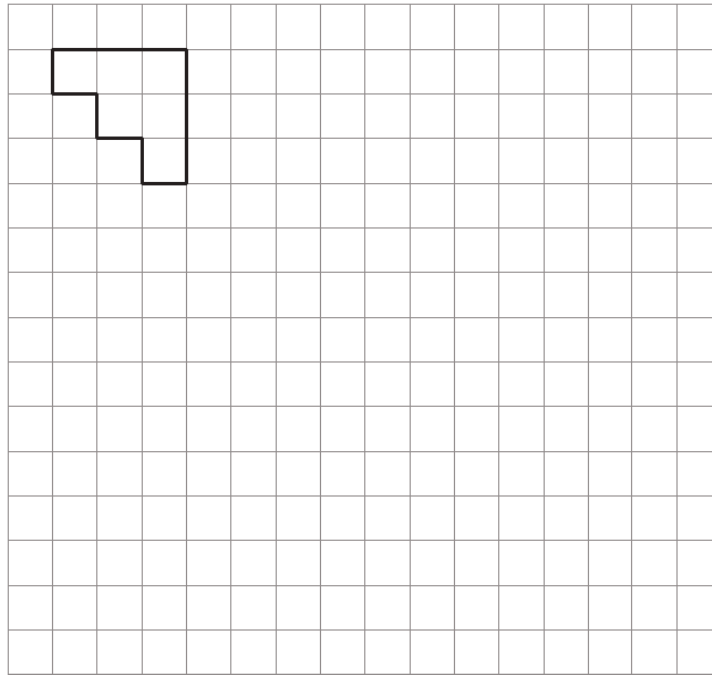

- (b) Translate the shape below 2 squares to the left and 4 squares down.

[1]

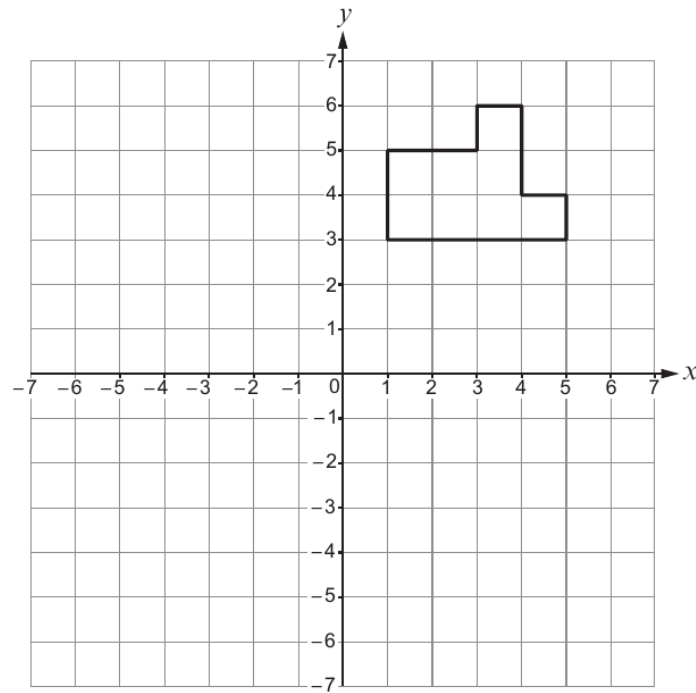

Examiner
only

12. Using only the numbers in the following list,

31 33 35 37 39 41 43

find

(a) the multiple of 5·5, [1]

.....

.....

.....

The multiple of 5·5 is

(b) the factor of 111. [1]

.....

.....

.....

The factor of 111 is

13. Shade the least number of squares so that the grid has rotational symmetry of order 2. The squares you shade must be in the lower two quadrants. [2]

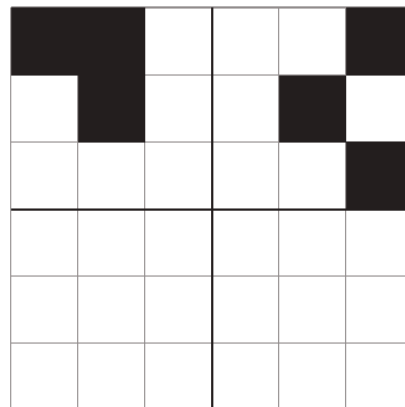

Examiner
only

7. (a) What is the special name given to an angle greater than 0° and less than 90° ? [1]

.....

(b) What is the special name of a quadrilateral with rotational symmetry of order four? [1]

.....

8. (a) Describe **in words** the rule for continuing each of the following sequences.

(i) 62, 51, 40, 29, ... [1]

Rule:

.....

.....

(ii) 2, 8, 32, 128, ... [1]

Rule:

.....

.....

(b) Solve the following equations.

(i) $4x = 124$ [1]

.....

.....

(ii) $w + 6 \cdot 9 = 110$ [1]

.....

.....

9. (a) Calculate $\frac{3}{8}$ of 142. [2]

Write your answer as a decimal.

.....

.....



Examiner only

10. A number machine is shown below.

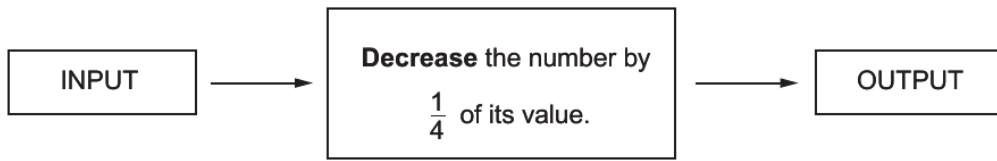

For a given INPUT number, there will be an OUTPUT number.
The OUTPUT is then put back in the number machine as the next INPUT.
This process is then repeated many times.

The first INPUT number is 512.
What will be the first OUTPUT number that is less than 300?

[4]

.....

.....

.....

.....

.....

.....

.....

.....

.....

.....

.....

.....

.....

.....

.....

.....

.....

.....

.....

.....

.....

.....

First OUTPUT number that is less than 300 =

3300U301
09



20. Rotate the shape shown below by 90° anticlockwise about the origin.

[2]

Examiner
only

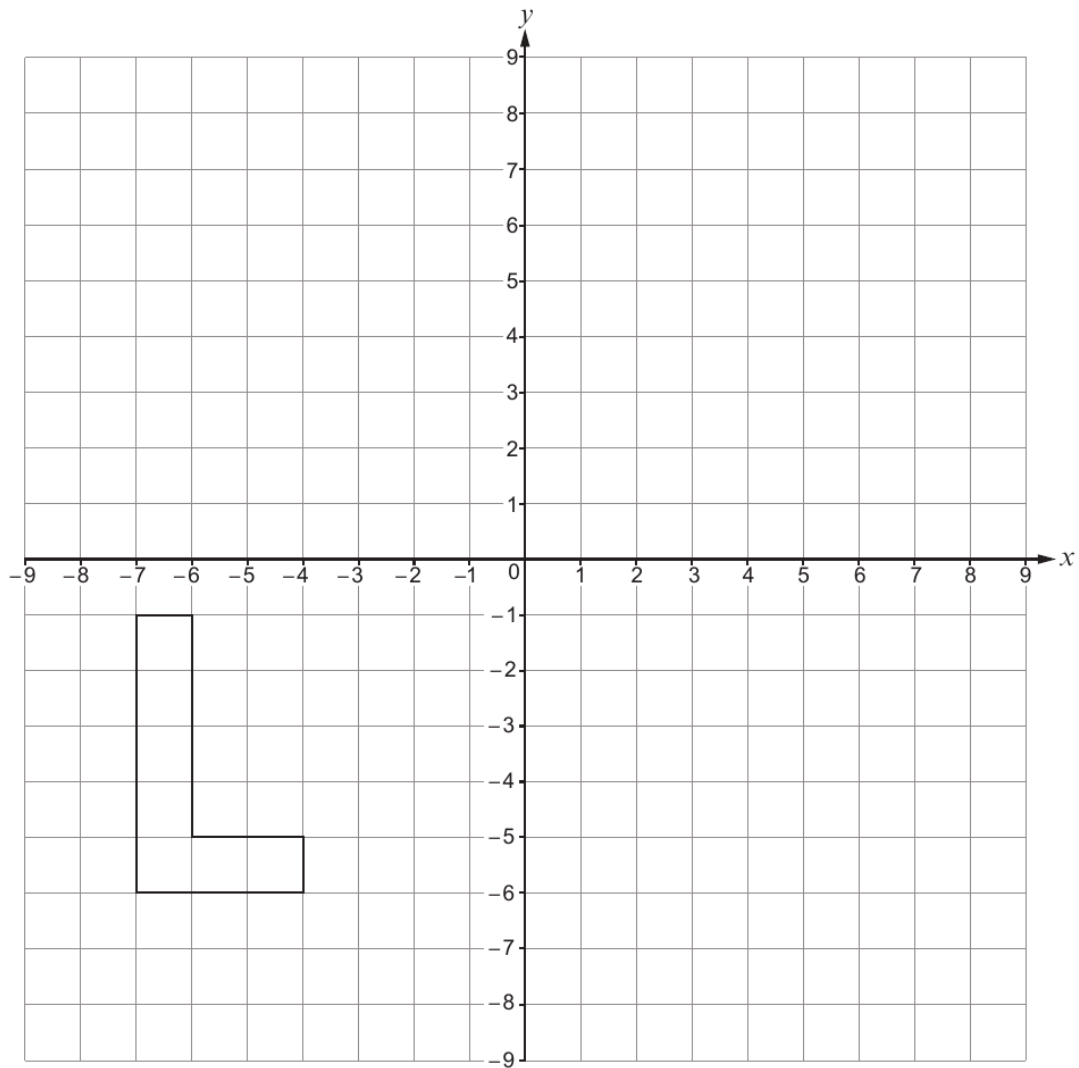

END OF PAPER



5. (a) Draw **all** the lines of symmetry on the shape below.

[2]

Examiner
only

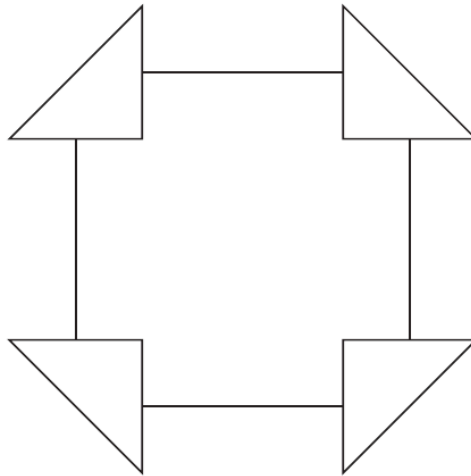

(b) What is the order of rotational symmetry of the shape below?

[1]

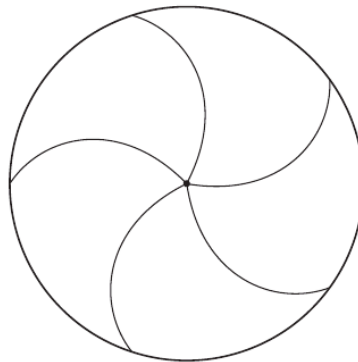

Order of rotational symmetry =

3300U101
07



Examiner
only

5. Treviso is a company that designs and builds bicycles.

(a) Treviso has designed this new bike frame. The missing angles need to be calculated.

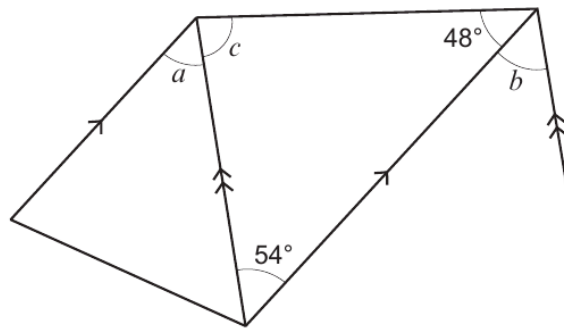

Diagram not drawn to scale

Find the size of each of the angles a , b and c .

[3]

.....

.....

$a = \dots\dots\dots^\circ$ $b = \dots\dots\dots^\circ$ $c = \dots\dots\dots^\circ$



Examiner
only

(b) Each wheel on Treviso's new bike has a diameter of 29 inches.

(i)

Remember: 1 foot = 12 inches

Ollie tests Treviso's new bike over a distance of 1000 feet.
How many times will a wheel rotate during the test?

[4]

.....

.....

.....

.....

.....

.....

(ii)

Remember: 12 inches ≈ 30 cm

What is the diameter of each wheel in **millimetres**?

[3]

.....

.....

.....

.....

.....

Diameter is mm

(c) Ollie uses the new bike in a 48 km race.
He completes the race in a time of 1 hour 30 minutes.
Calculate his average speed for the race.
Give your answer in km/h.

[3]

.....

.....

.....

.....

Average speed is km/h

3310U401
09



7. (a) Translate the triangle 6 squares to the left and 2 squares down.

[1]

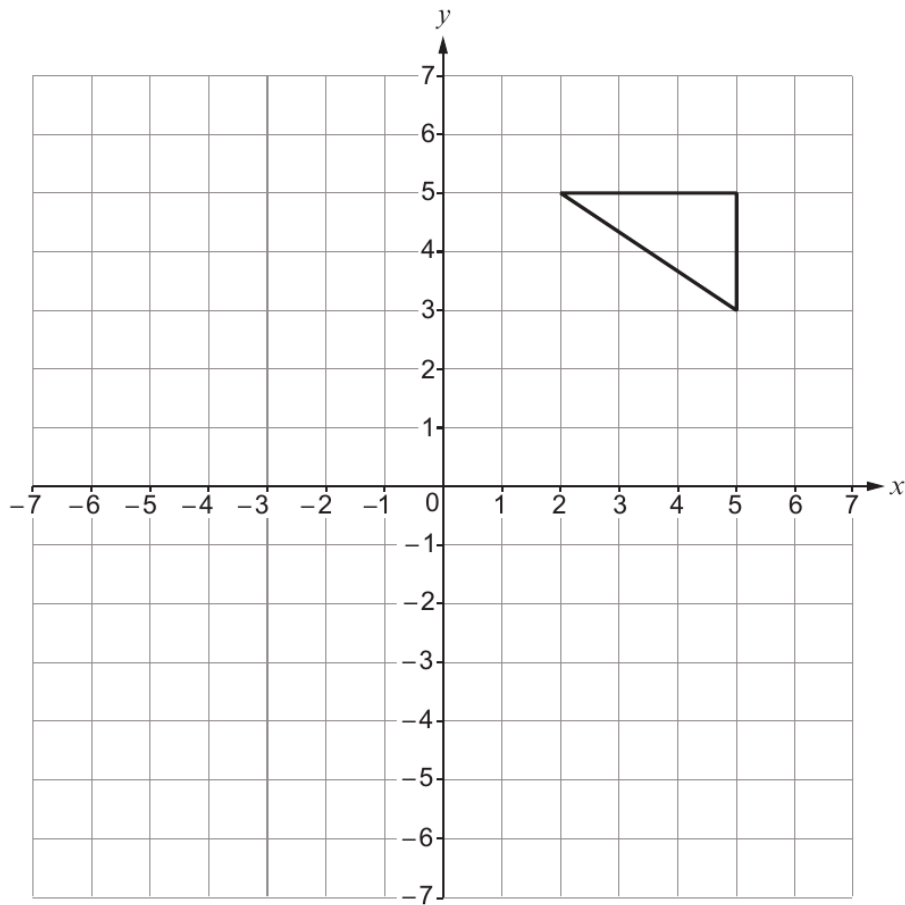
Examiner
only

(b) Reflect the triangle in the line $y = 1$.

[2]

Examiner only

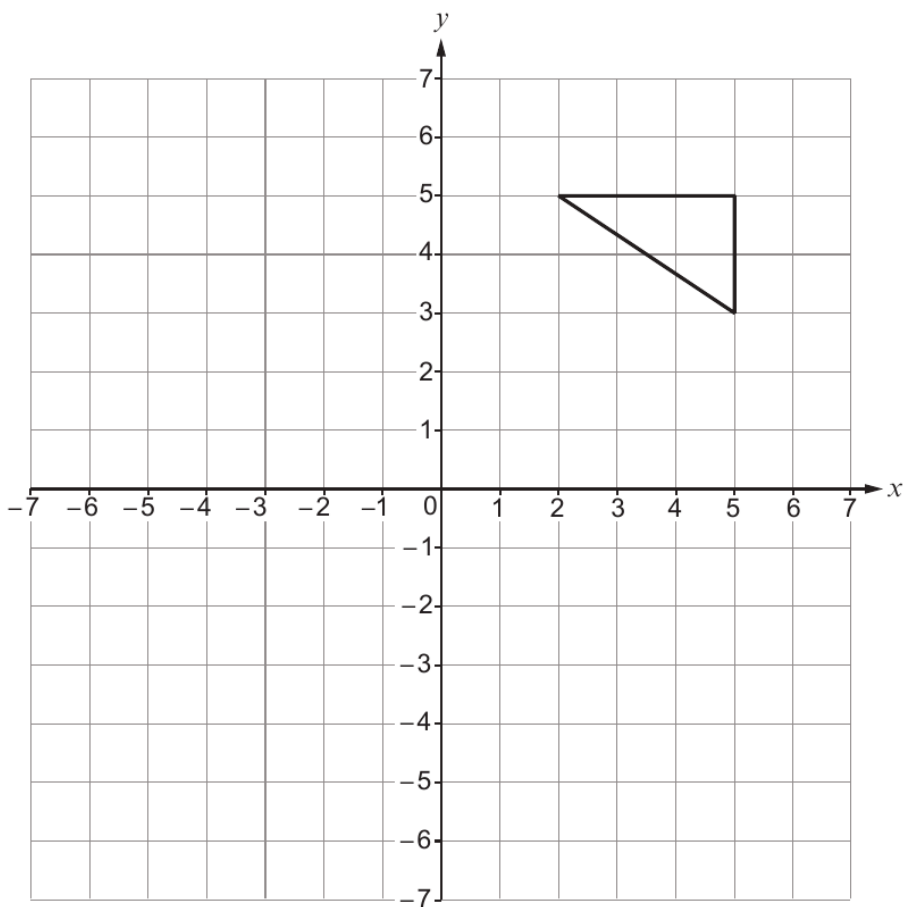

3300U401
09



16. (a) Translate the triangle 6 squares to the left and 2 squares down.

[1]

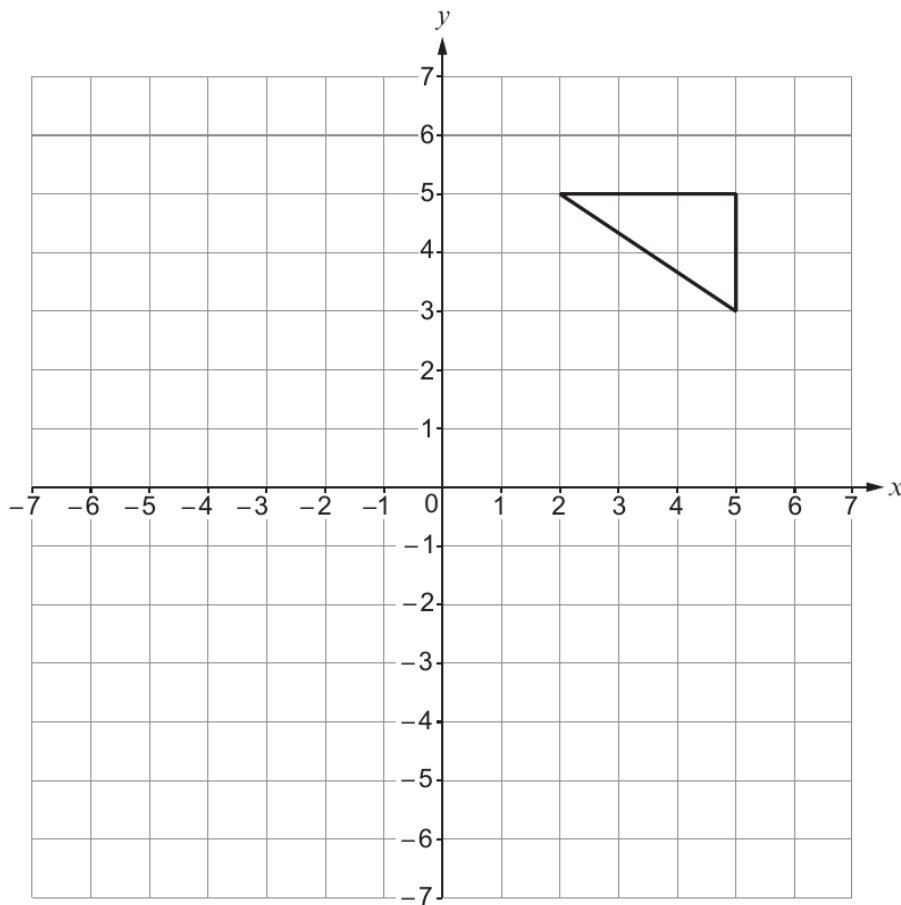
Examiner
only

(b) Reflect the triangle in the line $y = 1$.

[2]

Examiner
only

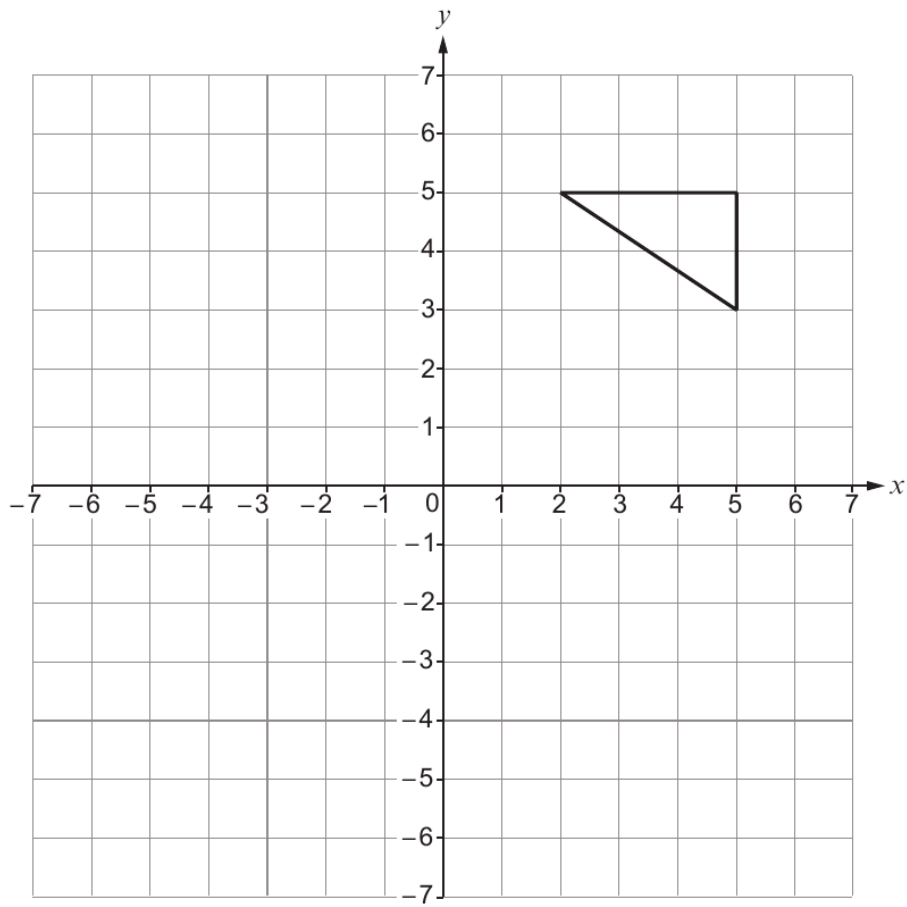

Examiner only

3. (a) Write down the special name of each shape below.

(i)

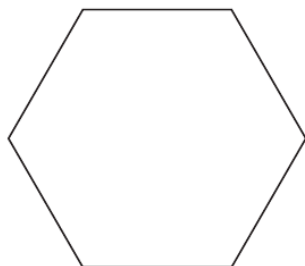

..... [1]

(ii)

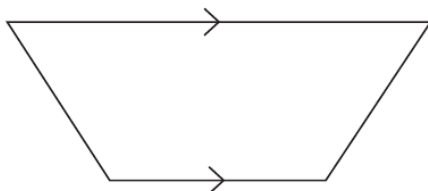

..... [1]

(b) Write down the special name of the 3D shape below.

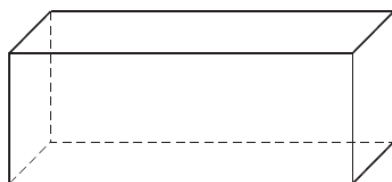

..... [1]

(c) A parallelogram is shown below.

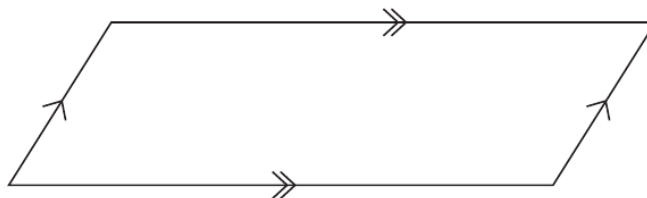

(i) What is the order of rotational symmetry of the parallelogram?
Circle the correct answer.

[1]

- 0 1 2 3 4

(ii) How many lines of symmetry does the parallelogram have?
Circle the correct answer.

[1]

- 0 1 2 3 4

3300U201
05



Examiner only

8. Ahmed organises a game using two fair spinners, as shown below.
The first spinner shows the values 10, 20, 30 and 40.
The second spinner shows the values 1, 2, 3, 4 and 5.

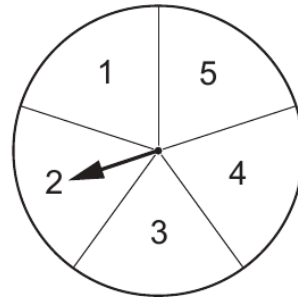
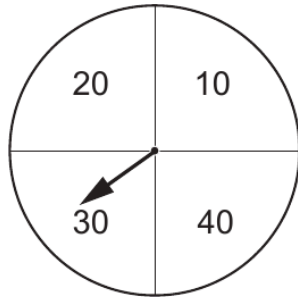

In the game, the two spinners are spun and the values shown are added to give a score.
For example, the spinners above score 32.

Ahmed charges £1 for each attempt at the game.
Any player who scores **43 or more** wins £5.

Calculate Ahmed's expected profit when this game is played 100 times.

[7]

.....

.....

.....

.....

.....

.....

.....

.....

.....

.....

.....

.....

.....

.....

.....

.....

.....

.....

.....

.....

.....

.....

.....

3300U301
09



19. (a) Reflect the shape A in the line $x = -1$.

[2]

Examiner
only

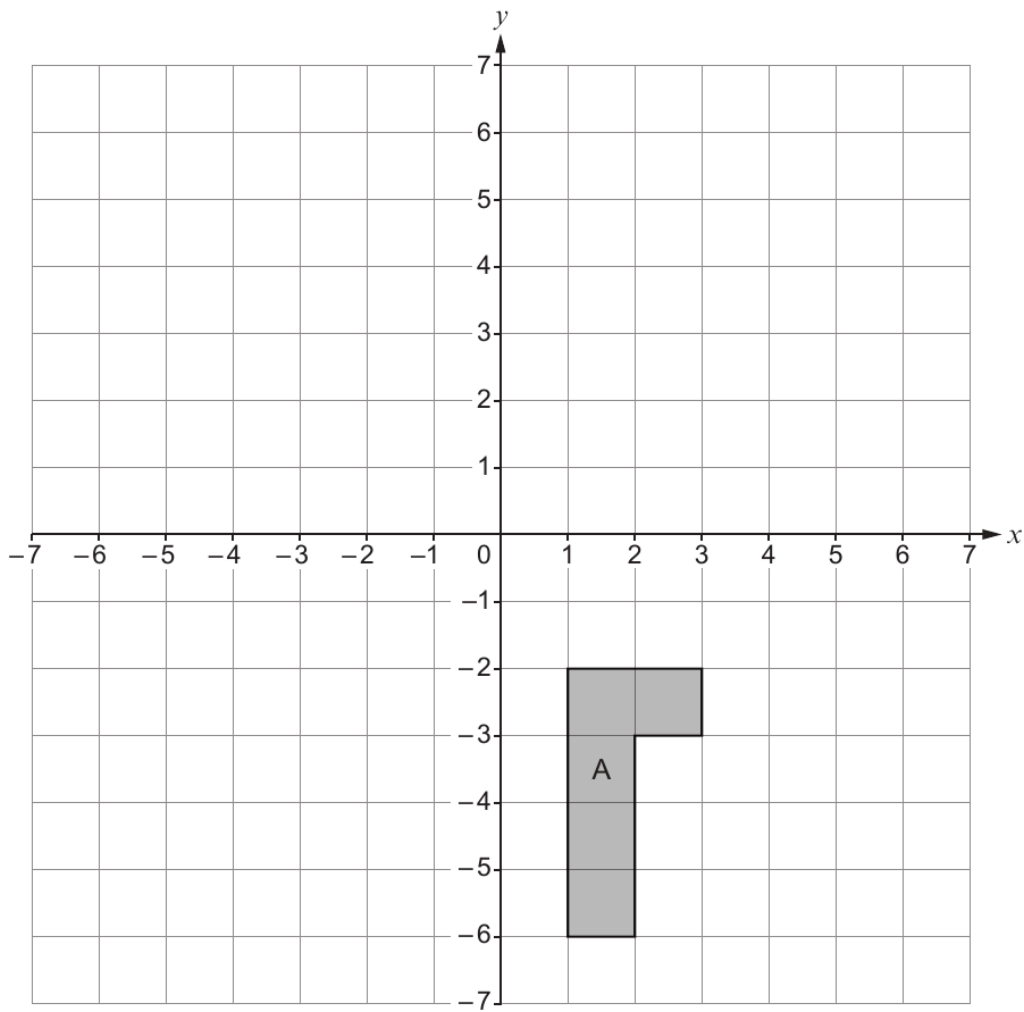

(b) Enlarge the shape B by a scale factor of 2, using (1, 3) as the centre of enlargement. [3]

Examiner
only

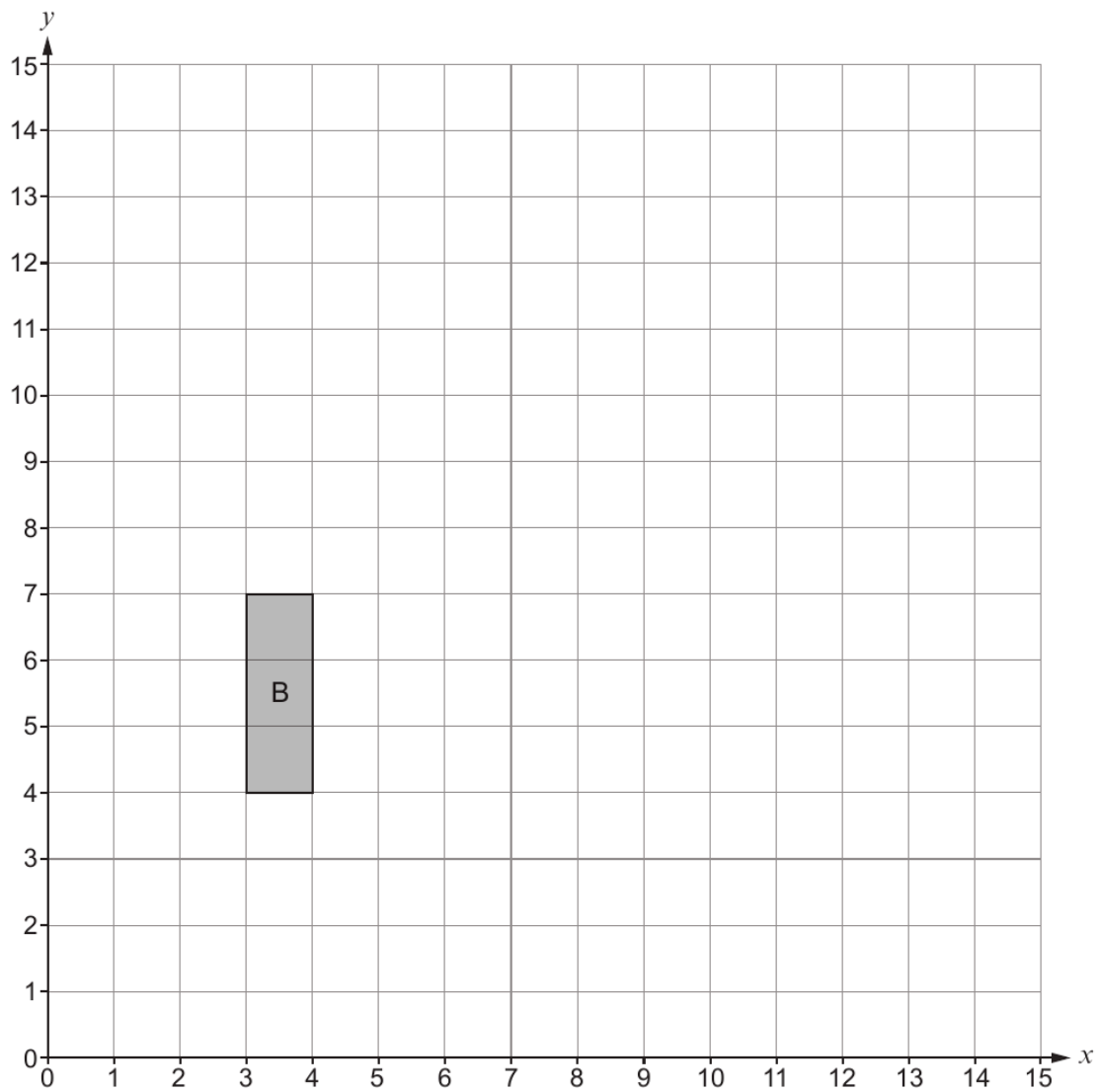

END OF PAPER



Examiner
only

3. (a) Calculate the following.

$$\frac{17}{50} \text{ of } 24.5 + 78\% \text{ of } 103.5$$

You must show all your working.

[2]

.....

.....

.....

.....

.....

- (b) Express £19.44 as a percentage of £36.

[2]

.....

.....

.....

.....

.....

4. Shade the least number of squares so that the grid has rotational symmetry of order 2. [3]

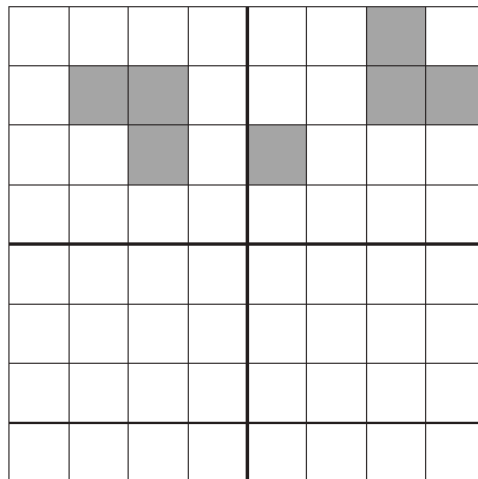

Examiner
only

8. The shape below has rotational symmetry of order 6.

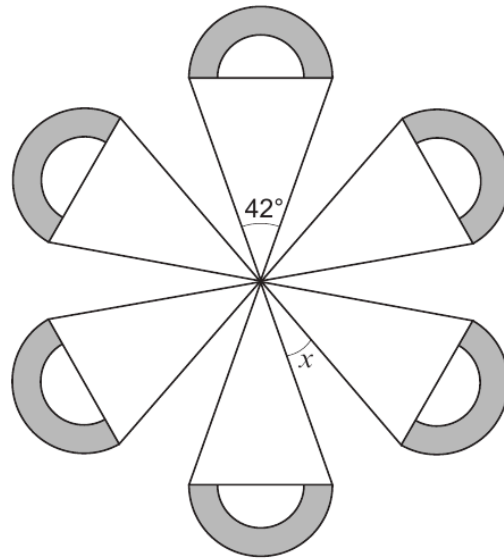

Diagram not drawn to scale

Find the size of angle x .
You must show all your working.

[4]

.....

.....

.....

.....

.....

.....

.....

.....

.....

.....

.....

.....

.....

.....

.....

.....

.....

.....

.....

.....

.....

.....



8. (a) Rotate the triangle through 90° clockwise, about the origin.

[2]

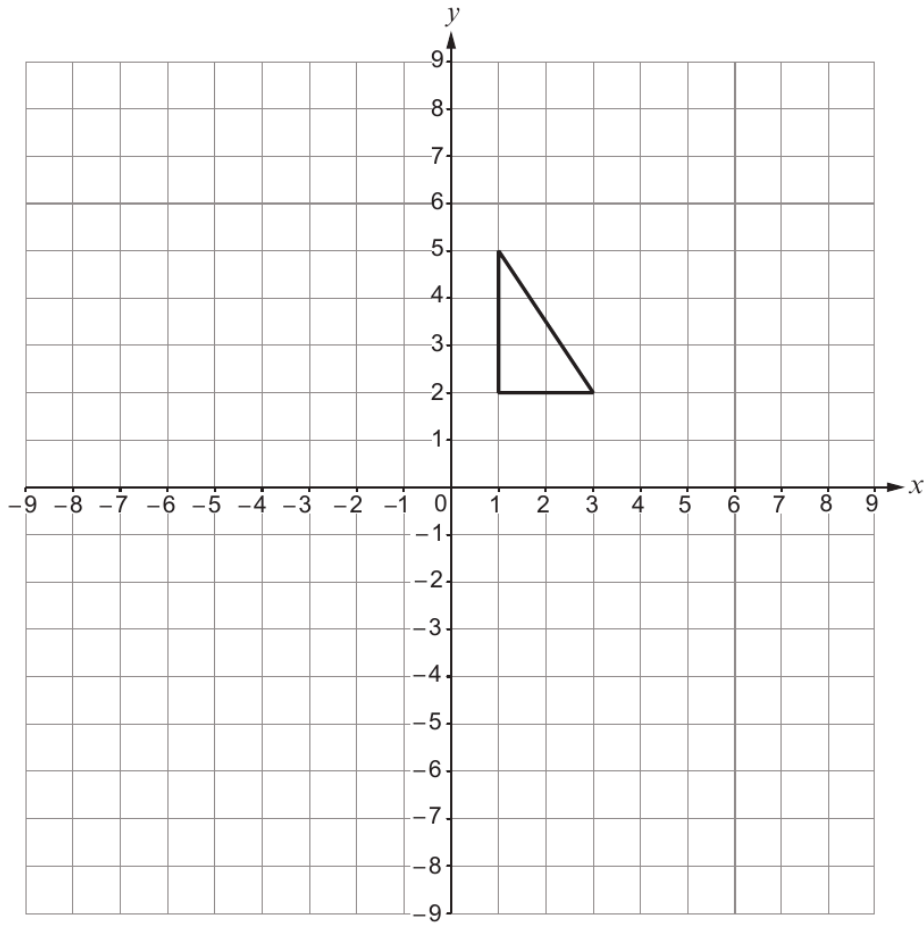
Examiner
only

(b) Reflect the triangle in the line $x = -2$.

Examiner only
[2]

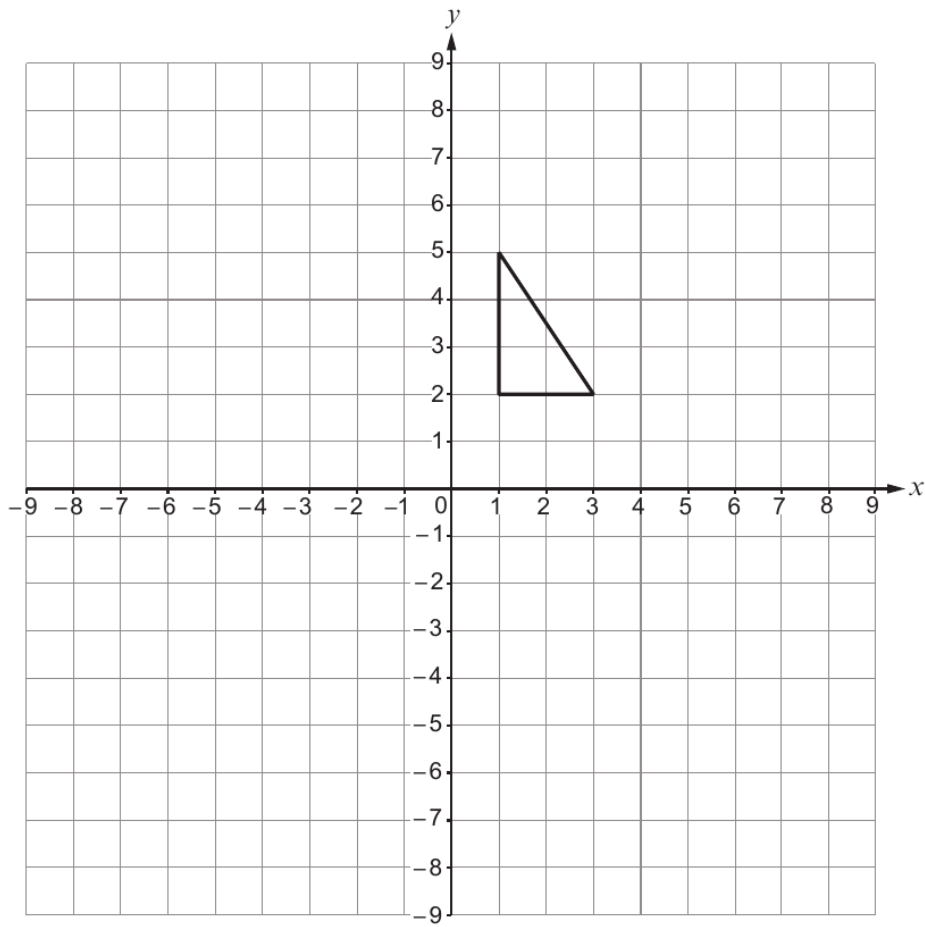

17. (a) Rotate the triangle through 90° clockwise, about the origin.

[2]

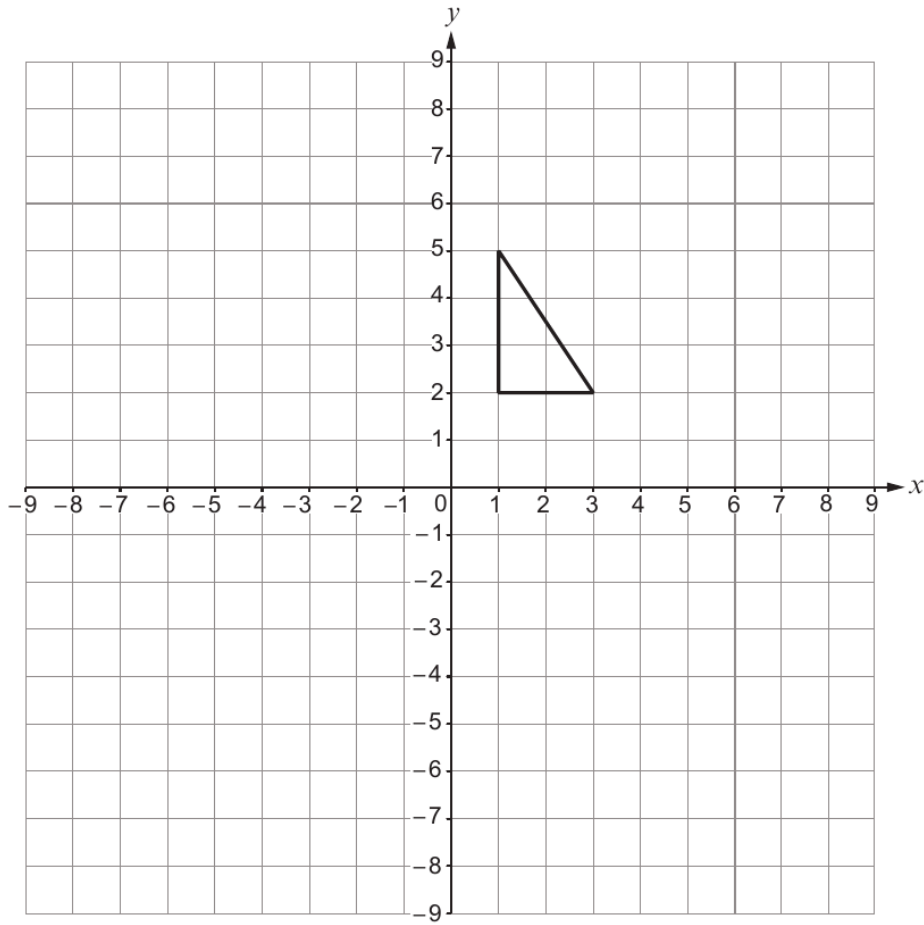
Examiner
only

(b) Reflect the triangle in the line $x = -2$.

[2]

Examiner
only

