

Name	Date started	Target end date
------	--------------	-----------------

WJEC GCSE Mathematics and Numeracy (Double Award) – Question Pack

Using scale drawings and maps to find real distances, and measuring or drawing bearings as three-figure angles measured clockwise from North. Sourced

REVISE
.wales

F1.18 – Maps, scale drawings & bearings

Spec 3.3.1, 3.3.2, 3.3.3, 3.3.4 – Unit 1 (calculator allowed)

Using scale drawings and maps to find real distances, and measuring or drawing bearings as three-figure angles measured clockwise from North. Sourced from legacy WJEC GCSE Mathematics-Numeracy Foundation papers (3300U10/U20) and accessible content from Intermediate papers (3300U30/U40), organised for revision under the 2025 spec.

2025 SPECIFICATION

Estimated time for entire question pack: ~2 hours 10 minutes

Derived from the GCSE Higher pace of ~1.5 min/mark (87 marks across 83 questions).

*You are advised to **not** attempt to complete all of this in one sitting.*

ABOUT THIS QUESTION PACK

This is a **focused single-topic practice pack**, not a single mock paper. Questions are organised against the 2025 specification. Questions are ordered chronologically by sitting, with custom-written and SAM questions at the end.

INSTRUCTIONS

Use black ink or black ball-point pen. Show all working – method marks are awarded for clear setup.

A calculator is allowed on every question in this pack (Unit 1 is the calculator-allowed paper).

All question content is © WJEC CBAC Ltd. and reproduced for revision purposes only.

Maps, scale drawings & bearings – what the new spec asks

WJEC GCSE Mathematics (first teaching 2025) · Unit 1: calculator-allowed.

Scale drawings 3.3.1

- Read a scale and convert map distance to real distance.
- Convert real distance to map distance for a drawing.
- Make a scale drawing of a given real-life situation.

Map ratios 3.3.2

- Interpret a ratio scale such as 1:25 000 or 1:200.
- Convert between cm, m and km when using scales.
- Use scales given as '1 cm represents 5 km'.

Bearings 3.3.3

- Measure a bearing of one point from another using a protractor.
- Draw a point on a given bearing and distance from another.
- Write bearings as three-figure angles from North.

Exam strategy 3.3

- Always draw a North line at the point you measure from.
- Write bearings with three digits, e.g. 075° not 75° .
- Sense-check distances against the scale before answering.

Maps, scale drawings & bearings in one page

Quick-reference notes – revisit before each question. Don't use during the questions.

Map scale ratio

Scale 1:N means 1 unit on the map = N units in real life.

1:50 000 → 1 cm on map = 50 000 cm = 500 m real.

Map to real distance

$$\text{real} = \text{map distance} \times \text{scale}$$

Measure the map distance in cm, multiply by the scale, convert to a sensible unit.

Real to map

$$\text{map} = \text{real distance} \div \text{scale}$$

Convert both to the same unit first (e.g. cm).

Bearings: what they are

Measured from North, clockwise.

Always written as three digits: 045°, 120°, 270°.

Measuring a bearing

Draw the North line at the start point.

Use a protractor, turn clockwise to the target.

North = 000° or 360°, East = 090°, South = 180°, West = 270°.

Back bearings & common traps

Back bearing = original ± 180°.

Traps: measuring anticlockwise, forgetting the leading zero, not adding the North arrow.

Examiner
only

3. (a) Reflect the triangle below in the x -axis.

[1]

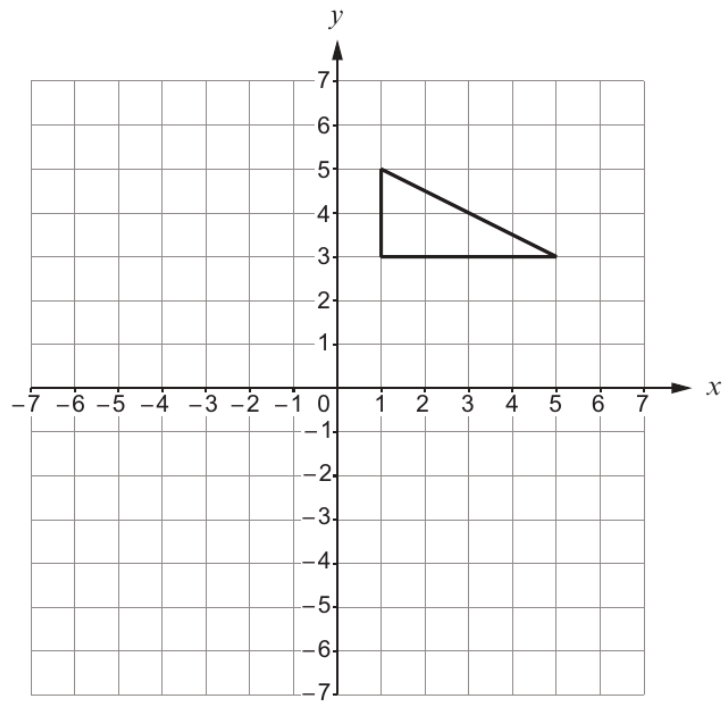

- (b) Enlarge the triangle below by a scale factor of 3.

[2]

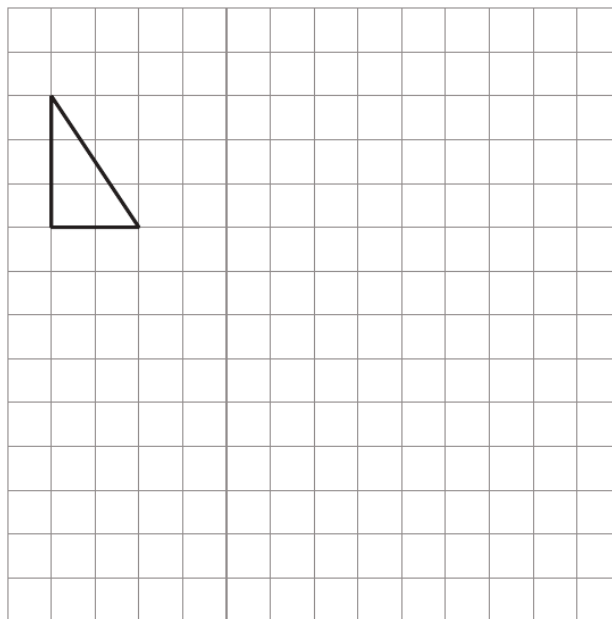

(c) Translate the triangle below 3 squares to the left and 2 squares down.

[1]

Examiner only

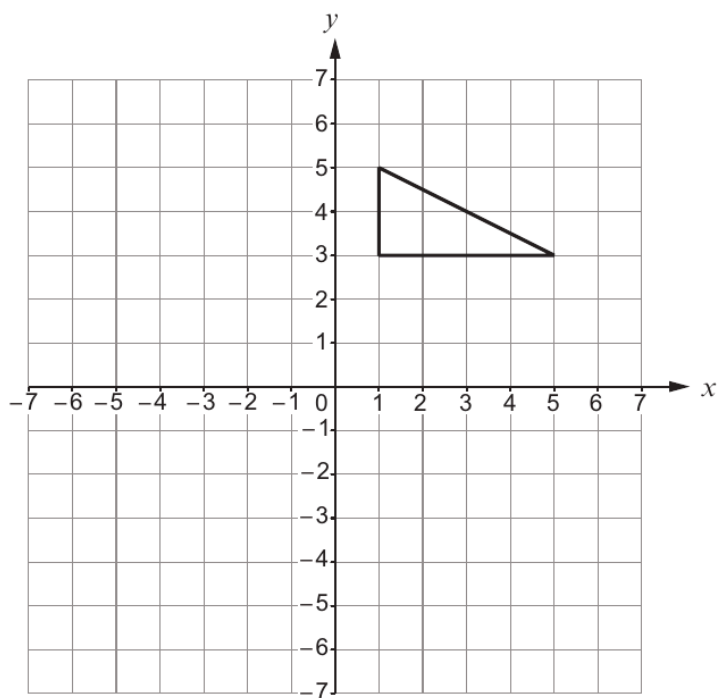

3300U301
05



Examiner only

7. $ABCD$ is a quadrilateral.

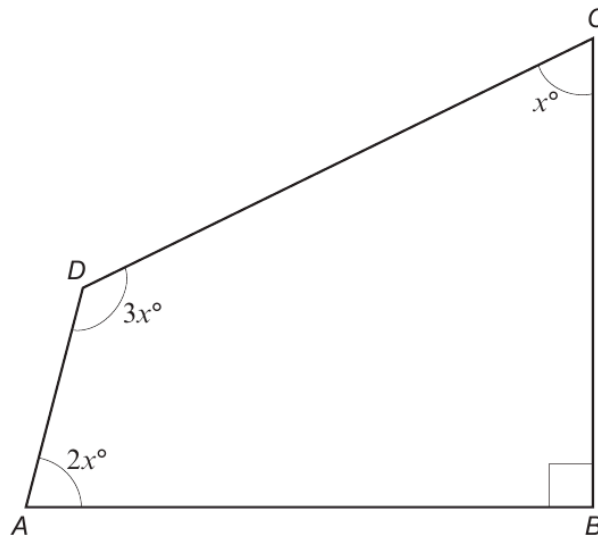

Diagram not drawn to scale

(a) Calculate the value of x . [4]

.....

.....

.....

.....

.....

(b) When $ABCD$ is drawn to scale, would the lines AD and BC be parallel or not? You must justify your answer without using a scale drawing. [2]

.....

.....

.....

.....

3300U301
09



13. Enlarge the triangle below by a scale factor of 3.

Examiner
only
[2]

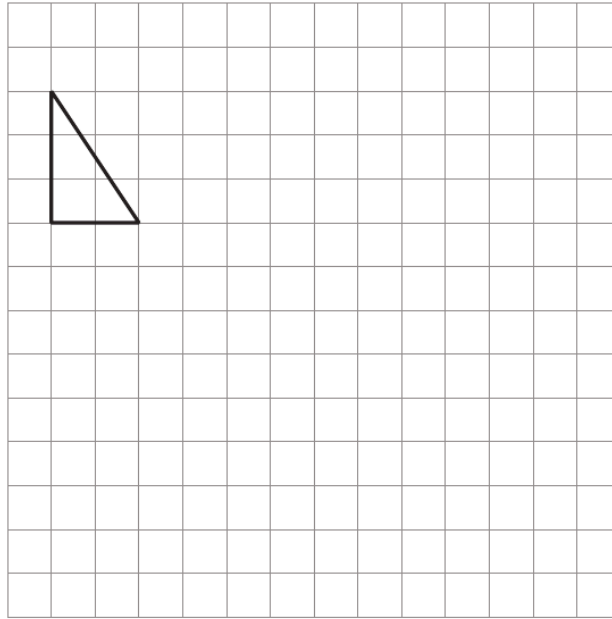

13. Circle either TRUE or FALSE for each of the following statements.

[3]

Examiner only

A triangle with one angle equal to 70° could be an equilateral triangle.	TRUE	FALSE
A triangle with one angle equal to 70° could be an isosceles triangle.	TRUE	FALSE
A triangle with one angle equal to 70° could be a right-angled triangle.	TRUE	FALSE
An isosceles triangle could have one of its angles equal to 105° .	TRUE	FALSE
A right-angled triangle could have one of its angles equal to 105° .	TRUE	FALSE

.....

.....

.....

.....

.....

.....

14. Calculate the answer when,

'the largest prime number that is a factor of 28'
is multiplied by
'the smallest prime number that is factor of 15'.

[2]

.....

.....

.....

.....

.....



Examiner
only

14. A right-angled triangle LMN is shown below.
 $LN = 16.9$ cm and $LM = 6.5$ cm.

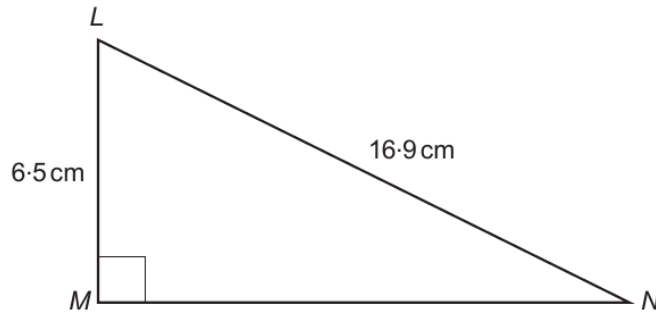

Diagram not drawn to scale

Calculate the length MN .

[3]

.....

.....

.....

.....

.....

.....

.....

.....

.....

.....



Examiner
only

15. Team A and Team B play in a competition.

Team A has nine more points than Team B.
Team A has four times as many points as Team B.

How many points does each team have? [2]

.....

.....

.....

.....

.....

Team A: points

Team B: points



Examiner
only

15. In the following formulae, each measurement of length is represented by a letter.

Consider the dimensions implied by the formulae.

Write down, for each case, whether the formula could be for a length, an area, a volume or none of these.

The first one has been done for you.

[3]

<u>Formula</u>	<u>Formula could be for</u>
$d^3 - 3 \cdot 14r^2h$ volume
$d^2 + hw$
$d + w + h$
$2\pi r - \pi r^2$
$(d + h)w$
$d^3 + dwh$



Examiner
only

17. $ABCD$ is a quadrilateral.

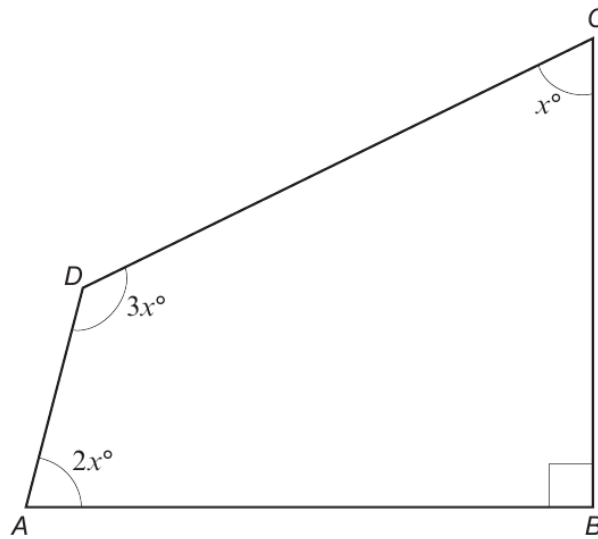

Diagram not drawn to scale

- (a) Calculate the value of x . [4]

.....

.....

.....

.....

.....

- (b) When $ABCD$ is drawn to scale, would the lines AD and BC be parallel or not? You must justify your answer without using a scale drawing. [2]

.....

.....

.....

.....



Examiner
only

11. (a) Calculate $\frac{145.3}{(12.4 - 9.8)^3}$, giving your answer correct to 3 significant figures. [2]

.....

(b) Calculate the reciprocal of 47, giving your answer correct to 4 decimal places. [2]

.....

12. Circle the correct answer in each of the following.

(a) Which of the following values **cannot** be an external angle of a regular polygon? [1]

- 10° 18° 30° 48° 72°

.....

(b) An arrow on a spinner is facing north.
 It is turned clockwise through an angle of 1530°.
 In which direction will the arrow now be facing? [1]

- North East South West None of these

.....

(c) Point A is on a bearing of 100° from point B.
 What is the bearing of point B from point A? [1]

- 260° 100° 280° 180° 80°



Examiner only

13. (a) The square drawn below has rotational symmetry of order 4.
Place **two** identical dots (●) on the square so that it will have rotational symmetry of order 2. [1]

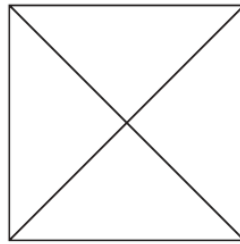

- (b) The regular hexagon drawn below has rotational symmetry of order 6.
Place **three** identical dots (●) on the regular hexagon so that it will have rotational symmetry of order 3. [1]

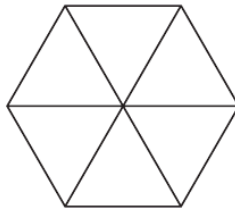

- (c) Which of the following shapes has rotational symmetry of order 3, but has **no** line symmetry?
Circle the correct shape. [1]

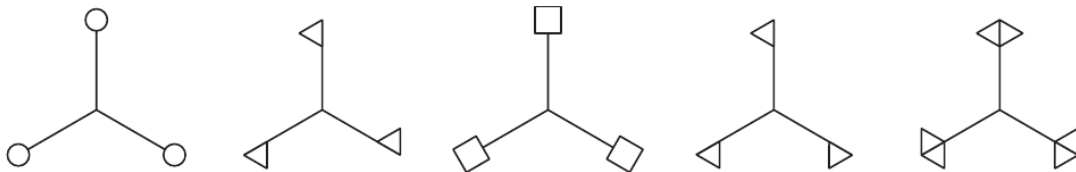

Examiner
only

14. (a) Calculate the value of $(2 \times 10^{-4}) \times (7.8 \times 10^9)$.
Give your answer in standard form. [2]

.....

.....

.....

.....

.....

(b) Calculate the value of $\frac{3.9 \times 10^8}{3000}$.
Give your answer in standard form. [2]

.....

.....

.....

.....

.....

15. Factorise $12x^2 + 3xy$. [2]

.....

.....

.....



Examiner
only

14. (a) The highest common factor (HCF) of 30 and 75 is the square root of a number.
What is the number? [2]

.....

.....

.....

.....

.....

.....

.....

(b) The cube root of 32·768 is $33\frac{1}{3}\%$ of a number.
What is the number? [2]

.....

.....

.....

.....

.....



15. The n th term of a sequence is given by $2n - 11$.

Write down the value of,

(i) the 10th term,

[1]

.....

.....

(ii) the 3rd term.

[1]

.....

.....

Examiner
only



2.

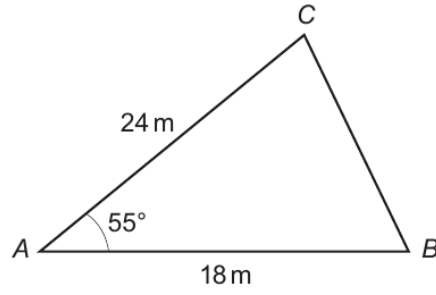

Diagram not drawn to scale

- (a) Draw an accurate scale drawing of the triangle shown above.
Use the scale:

1 centimetre represents 3 metres.

[3]

Examiner
only



5. (a) Estimate the answer to $\frac{59 \times 301}{1997}$.

You must show all your working.

[2]

.....

.....

.....

.....

- (b) Given that $341 \times 57 = 19\,437$, write down the answer to each of the following.

(i) 3.41×5.7

[1]

.....

(ii) $\frac{19\,437}{570}$

[1]

.....

.....

Examiner
only

3300U301
07



Examiner
only

14. Five numbers are listed below.

3 3 6 13 15

Write down another set of five **positive whole** numbers such that

- all the numbers are **less than 20**,
- the median of the new set of numbers is greater than the median of the set shown above,
- the mean of the new set of numbers is less than the mean of the set shown above,
- the range of the new set of numbers is less than the range of the set shown above.

Your set of whole numbers must be written in the boxes.

[3]

Space for working:

.....

.....

.....

.....

.....

.....

.....

.....

.....

.....

.....

.....

.....

.....

.....

.....

.....

.....

.....

.....

.....

.....

My five positive whole numbers are

--	--	--	--	--



14. (a) Solve $\frac{m}{2} = 4.8$.

[1]

Examiner
only

.....

.....

.....

(b) The n th term of a sequence is given by $3n - 20$.

What is the value of the 6th term?

[1]

.....

.....



15.

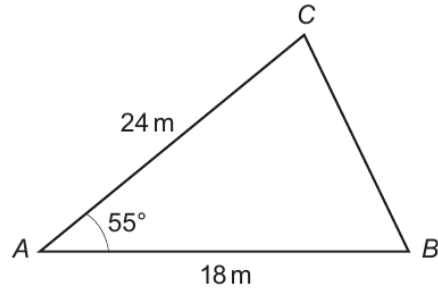

Diagram not drawn to scale

- (a) Draw an accurate scale drawing of the triangle shown above.
Use the scale:

1 centimetre represents 3 metres.

[3]

Examiner
only



Examiner
only

(b) Use your scale drawing to calculate the **actual** length of side *BC*.
Give your answer in metres.

[2]

.....
.....

Actual length of *BC* = metres

16. A triangle and a rectangle are shown below.

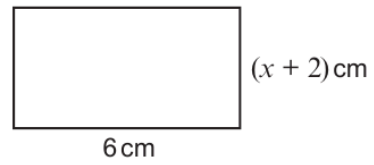
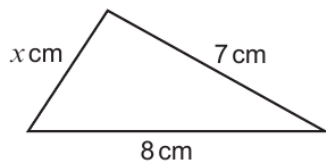

Diagrams not drawn to scale

The perimeter of the triangle is 18 cm.

Calculate the area of the rectangle.

[4]

.....
.....
.....
.....
.....
.....
.....



Examiner only

19. (a)

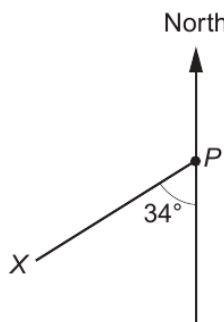

Diagram not drawn to scale

What is the bearing of X from point P?
Circle the correct answer.

[1]

- 146° 326° 214° 034° 234°

(b) The diagram below shows 6 points on a map. The diagram is drawn to scale.

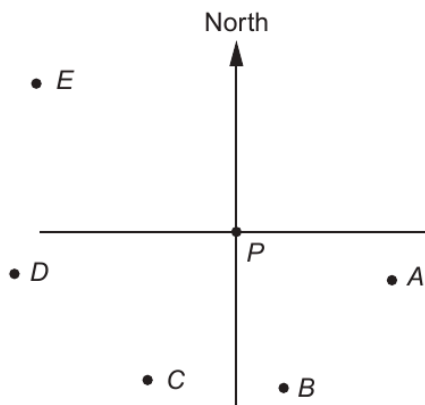

(i) A ship sails from point P on a bearing of 107°. It sails towards one of the five points A, B, C, D or E. Which of the five points is the ship sailing towards? Circle the correct answer.

[1]

- A B C D E

(ii) A second ship sails from point P for a number of miles on a bearing of 070°. It then changes direction and sails on a bearing of 270°. It is possible for the ship to reach **only one** of the five points A, B, C, D or E. Which point can the ship reach? Circle the correct answer.

[1]

- A B C D E



Examiner
only

12. In this question, you must use only the numbers 3 and 7 to make other numbers.
You must only add or subtract.

For example, if we wanted an answer of 11, we could write

$$7 + 7 - 3 = 11.$$

Show how you can get each of the following answers.

(a) 2

[1]

.....

.....

.....

Write your solution in the box below.

	= 2
--	-----

(b) 8

[1]

.....

.....

.....

Write your solution in the box below.

	= 8
--	-----

(c) 19

[1]

.....

.....

.....

Write your solution in the box below.

	= 19
--	------



14. Estimate the value of

$$\frac{30.21 \times 1.98^3}{0.49}$$

[3]

Examiner
only



Examiner
only

14. PQR is a right-angled triangle.
 $PR = 16.7$ cm, $QR = 9.6$ cm.

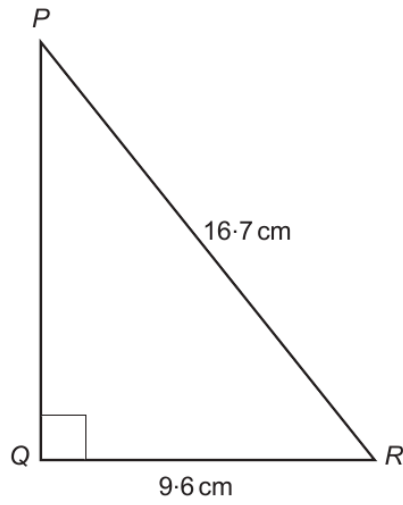

Diagram not drawn to scale

Calculate the size of \hat{QPR} .

[3]

.....

.....

.....

.....

.....

.....

.....

.....

.....

.....

.....



15. 18% of £256 is shared in the ratio 2 : 1.
Calculate the value of the larger share.
Give your answer to the nearest 10p.

You must show all your working.

[5]

Examiner
only

.....

.....

.....

.....

.....

.....

.....

.....

.....

.....

.....

.....

.....

.....

.....

.....



Examiner only

4. The mean of two numbers is 7.
The range of these two numbers is 8.

What are these two numbers?

[2]

.....

.....

.....

.....

.....

.....

The numbers are and

- 5.

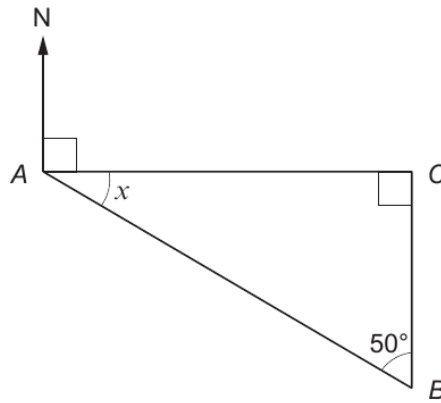

Diagram not drawn to scale

Calculate the size of angle x .
Hence, give the bearing of point B from point A .

[3]

.....

.....

.....

.....

.....

$x = \dots\dots\dots^\circ$ Bearing of point B from point $A = \dots\dots\dots^\circ$

3300U301
05



13. (a) Calculate the value of $3x + 4y$ when $x = -6$ and $y = 5$.

[2]

Examiner
only

.....

.....

.....

(b) Simplify the expression $9g - 4f - 3g - 5f$.

[2]

.....

.....

(c) Expand $4(3x - 5)$.

[1]

.....

.....



13. Fill in the boxes so that the following addition is correct.

[3]

Examiner
only

$$\begin{array}{r} \boxed{1} \quad \boxed{} \quad \boxed{9} \\ \boxed{7} \quad \boxed{8} \quad \boxed{} \quad + \\ \hline \boxed{} \quad \boxed{4} \quad \boxed{1} \\ \hline \end{array}$$

Space for working:

.....

.....

.....

.....

.....

.....



Examiner
only

13. Sian thinks of a number.
Its value is increased by 25%.

Express the original number as a percentage of the increased number.

[3]

.....

.....

.....

.....

.....

.....

.....

.....

14. Calculate the length of the side MN in the triangle LMN shown below.

[3]

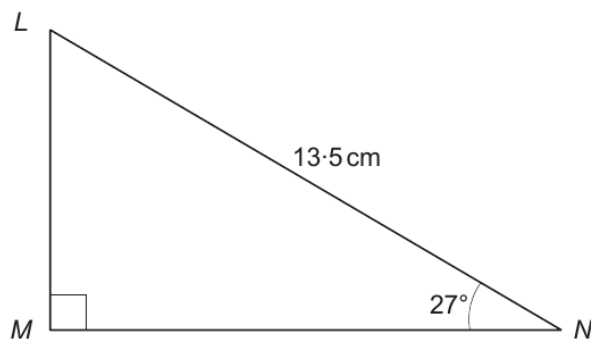

Diagram not drawn to scale

.....

.....

.....

.....

.....

.....

.....

.....



Examiner
only

14. The mean of two numbers is 7.
The range of these two numbers is 8.

What are these two numbers?

[2]

.....

.....

.....

.....

.....

.....

The numbers are and

- 15.

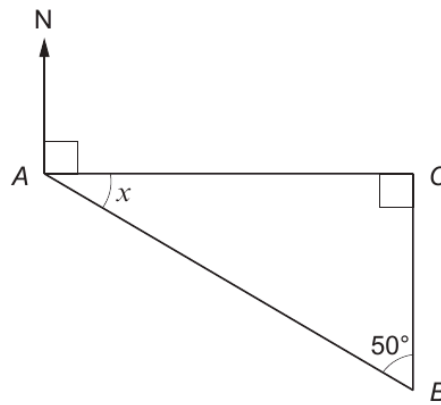

Diagram not drawn to scale

Calculate the size of angle x .
Hence, give the bearing of point B from point A .

[3]

.....

.....

.....

.....

.....

$x =$ $^{\circ}$ Bearing of point B from point $A =$ $^{\circ}$



Examiner
only

15. Circle the correct answer for each of the following.

(a) $81 =$

[1]

3^3

9^3

9^4

18^2

3^4

.....

.....

(b) $2 \cdot 15 =$

[1]

$32 \cdot 5$

$10 \cdot 5$

$40 \cdot 84101$

$30 \cdot 84101$

$32 \cdot 1$

.....

.....

(c) $(12 \cdot 96)^{\frac{1}{2}} =$

[1]

$6 \cdot 48$

$3 \cdot 6$

$4 \cdot 32$

$3 \cdot 3$

$2 \cdot 16$

.....

.....



Examiner only

9. (a) Two sides of a parallelogram $ABCD$ are drawn accurately below. Using only a ruler and a pair of compasses, complete an accurate drawing of the parallelogram. You must show all your construction arcs. [2]

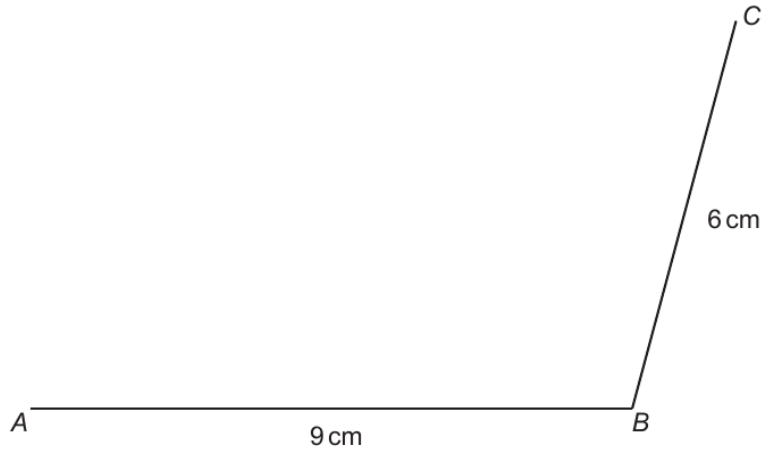

- (b) The line XY below forms part of a scale drawing of a garden. The scale drawing has a scale of 1:200. What is the actual distance between point X and point Y in the garden? Give your answer in **metres**. [3]



.....

.....

.....

.....

Actual distance between point X and point Y = metres

3300U301
11



Examiner
only

13. (a) What is the time 8 hours and 40 minutes after 11:38? [1]

.....
.....
.....

Time is

(b) What is the time difference between 7:35 a.m. and 2:15 p.m. on the same day?
Give your answer in hours and minutes. [1]

.....
.....
.....
.....

Time difference is hours and minutes.

(c) Evaluate the time difference between 7 minutes 15 seconds and 2 minutes 50 seconds.
Give your answer in seconds. [2]

.....
.....
.....
.....

Time difference is seconds.

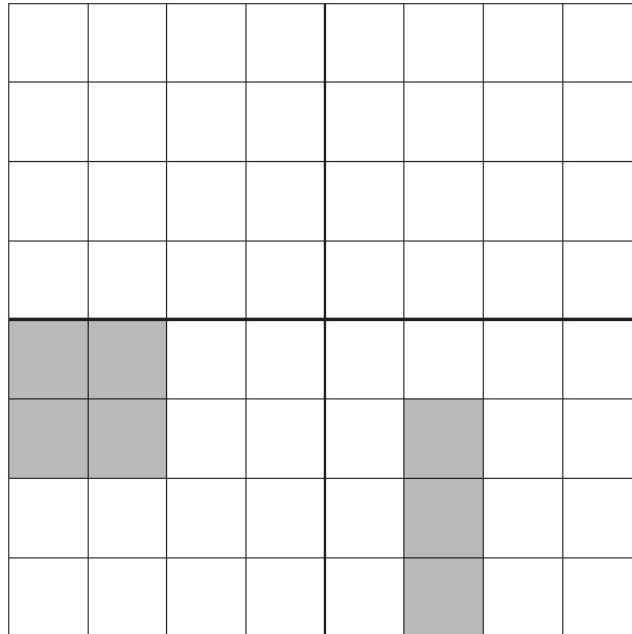

13. (a) Shade the least number of squares so that the grid has rotational symmetry of order 2. The squares you shade must be in the upper two quadrants. [2]

Examiner
only

(b) Describe fully the **single** transformation that transforms shape A onto shape B. [2]

Examiner only

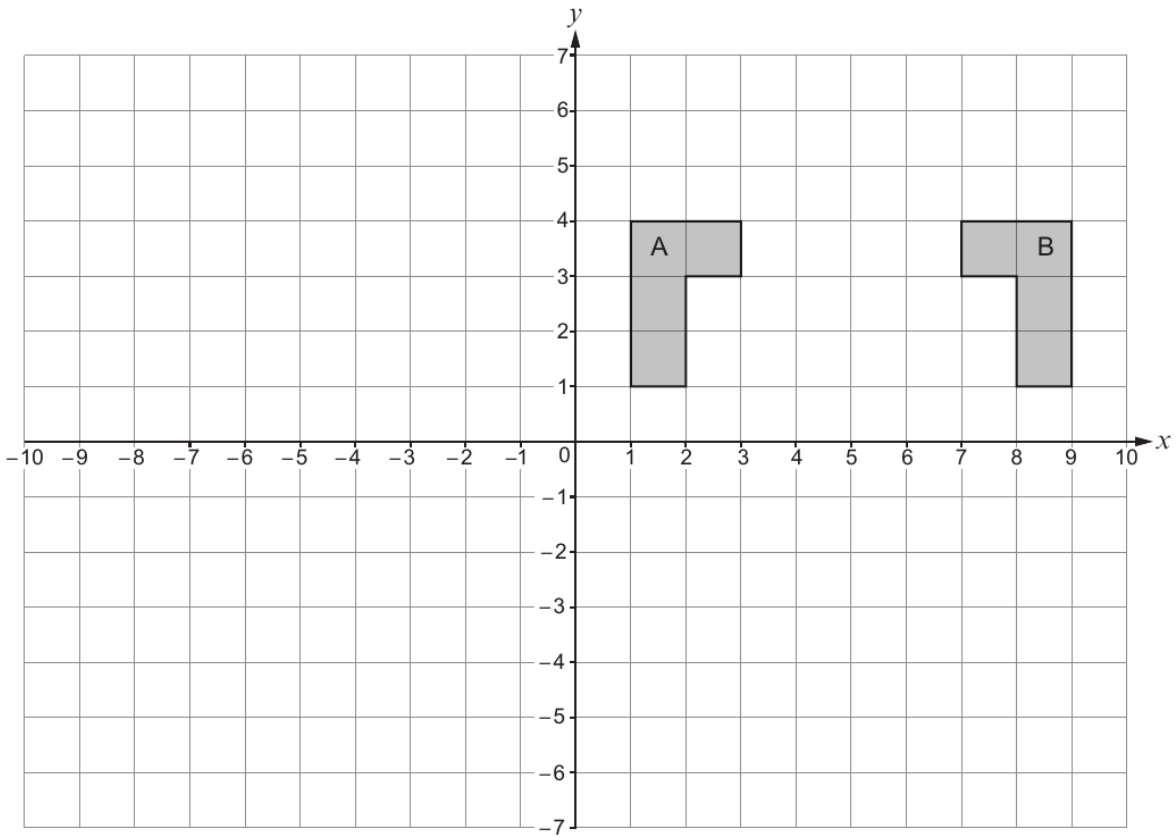

.....

.....

.....

.....



Examiner
only

13. (a) Which one of the following options describes $2x + 5y$?
Circle your answer. [1]

- an equation a formula an expression
- an inequality none of these

(b) Which one of the following options describes $3x - 2 = 7$?
Circle your answer. [1]

- an equation a formula an expression
- an inequality none of these

14. Data for different values of t are shown in the table below.

t	Frequency
$0 \leq t < 5$	8
$5 \leq t < 10$	0
$10 \leq t < 15$	7
$15 \leq t < 20$	5

Calculate an estimate for the mean value of t . [4]

.....

.....

.....

.....

.....

.....

.....

.....



Examiner
only

15. Find four **different** positive whole numbers so that:

- their mean is 8,
- their range is 8,
- their median is 8.

Write your four numbers in the boxes below.

[3]

.....

.....

.....

.....

.....

.....

.....

.....

.....

.....

.....

.....

.....

.....

.....

.....

The four numbers are

--	--	--	--



Examiner only

19. (a) Two sides of a parallelogram $ABCD$ are drawn accurately below. Using only a ruler and a pair of compasses, complete an accurate drawing of the parallelogram. You must show all your construction arcs. [2]

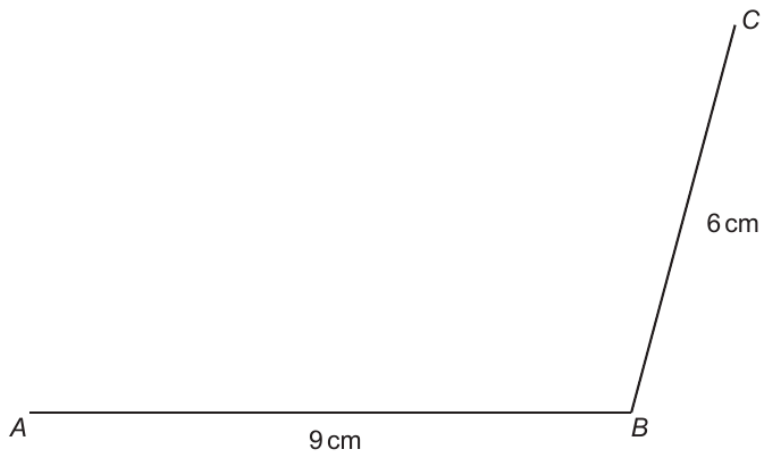

- (b) The line XY below forms part of a scale drawing of a garden. The scale drawing has a scale of 1:200. What is the actual distance between point X and point Y in the garden? Give your answer in **metres**. [3]



.....

.....

.....

.....

Actual distance between point X and point Y = metres



Examiner
only

11. (a) *In this part of the question, you will be assessed on the quality of your linguistic and mathematical accuracy in writing.*

Solve $7x - 3 = 11$.

[2 + 1 W]

.....

.....

.....

.....

.....

(b) Find the value of $3f + 2g$ when $f = 5.8$ and $g = -3.7$.

[2]

.....

.....

.....

.....



Examiner
only

14. (a) Rearrange the following formula to make k the subject.

$$p = 3k + 2 \quad [2]$$

.....

.....

.....

- (b) Does the midpoint of the straight line joining points (3, 15) and (7, 19) lie on the line $y = 3x + 2$?
You must show all your working. [3]

.....

.....

.....

.....

.....

.....

.....

15. (a) Express 0.0058 in standard form. [1]

.....

- (b) Calculate the value of $\frac{1.4 \times 10^9}{2 \times 10^3}$.
Give your answer in standard form. [2]

.....

.....

.....



14. Calculate the length of the side AB in the triangle shown below.

[3]

Examiner
only

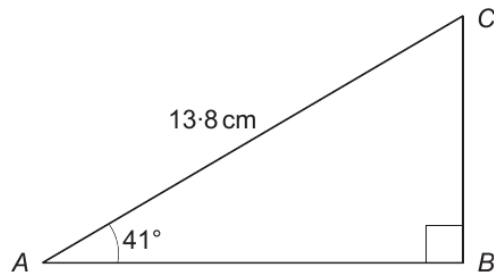

Diagram not drawn to scale

.....

.....

.....

.....

.....

.....

.....

.....

.....



Examiner only

14.

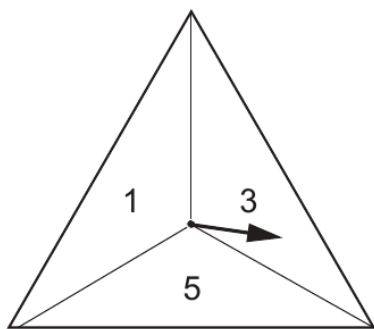

Triangular spinner

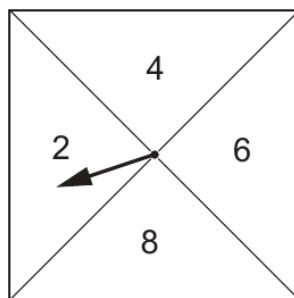

Square spinner

Two fair spinners are shown in the diagram above. In a game, the two spinners are spun.

The two numbers obtained are multiplied together to get a score. For example, in the diagram above, the score is 6 because $3 \times 2 = 6$.

Some of the scores are shown in the table below.

		Square spinner			
		2	4	6	8
Triangular spinner	1		4		8
	3	6		18	24
	5		20		

(a) Complete the table to show all the possible scores. [1]

.....

.....

(b) Explain why all the scores are even numbers. [1]

.....

.....

.....



Examiner only

15. In the diagram:
- AB and ED are parallel
 - triangles ABC and DEC are similar.

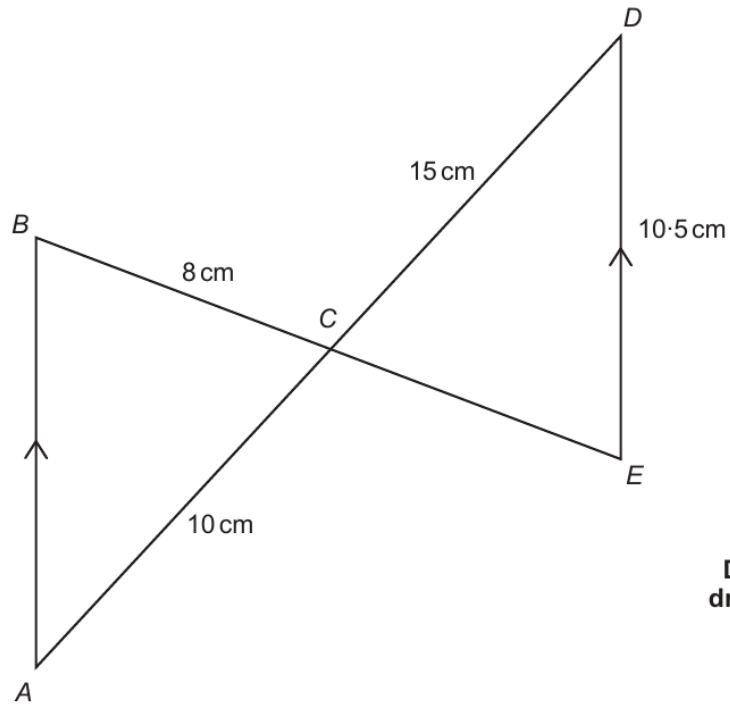

Diagram not drawn to scale

- (a) Calculate the length of CE . [2]

.....

.....

.....

.....

.....

- (b) Calculate the length of AB . [2]

.....

.....

.....

.....

.....



1. (a) Enlarge the shape below by a scale factor of 3.

Examiner only
[2]

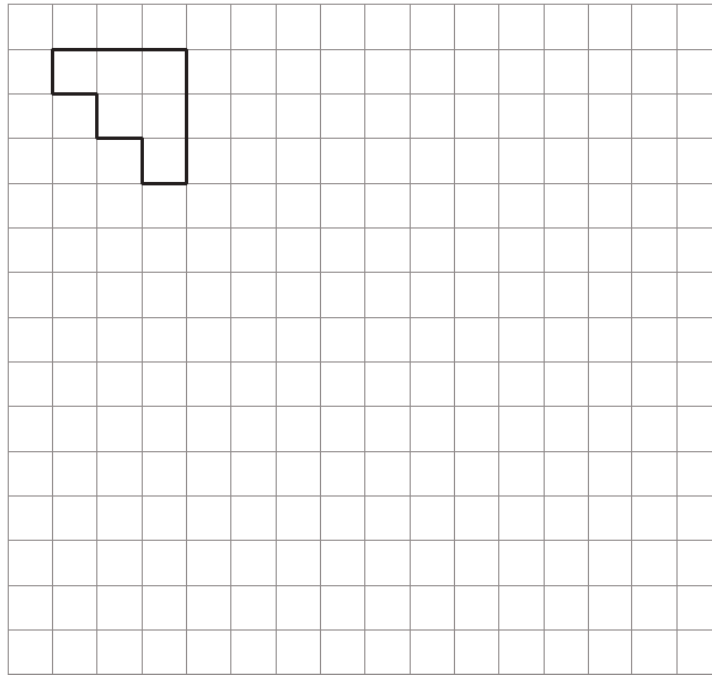

- (b) Translate the shape below 2 squares to the left and 4 squares down.

[1]

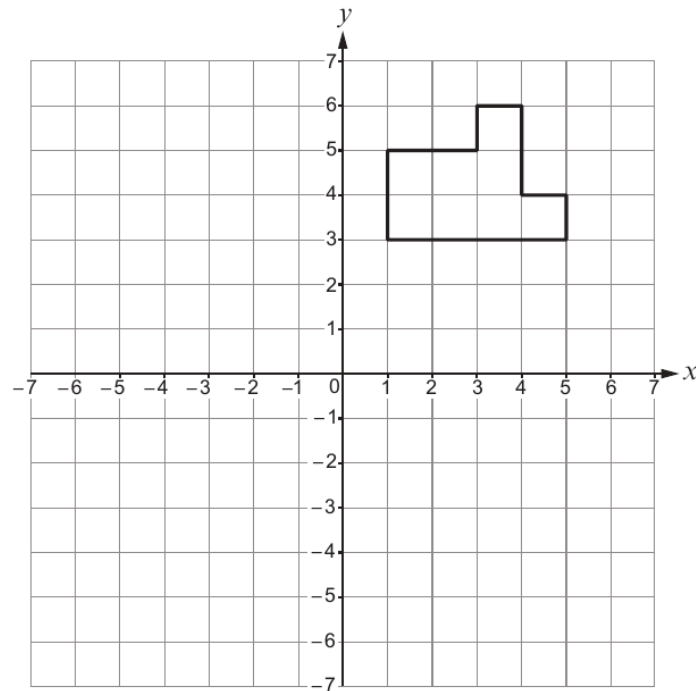

3300U401
03



Examiner
only

7. Most numbers have an **even** number of factors.
For example,
7 has **two** factors: 1 and 7.
8 has **four** factors: 1, 2, 4 and 8.

Some numbers have an **odd** number of factors.

There is one number between 14 and 20 that has an **odd** number of factors.
Find this number.
Write down all the factors of this number.
You must show all your working. [2]

.....

.....

.....

.....

.....

.....

.....

.....

.....

.....

.....

.....

.....

.....

.....

.....

.....

.....

.....

.....

.....

.....

The number is

The factors of this number are

8. Calculate each of the following.

(a) 2·7 squared [1]

.....

(b) the square root of 11·56 [1]

.....

(c) 60% of 28 [2]

.....

.....



Examiner only

9. Point A and point B are shown in the scale drawing below.

- (a) Point C is 35 km from point B on a bearing of 300° . Complete the scale drawing to show the position of point C. [2]

Scale: 1 cm represents 5 km

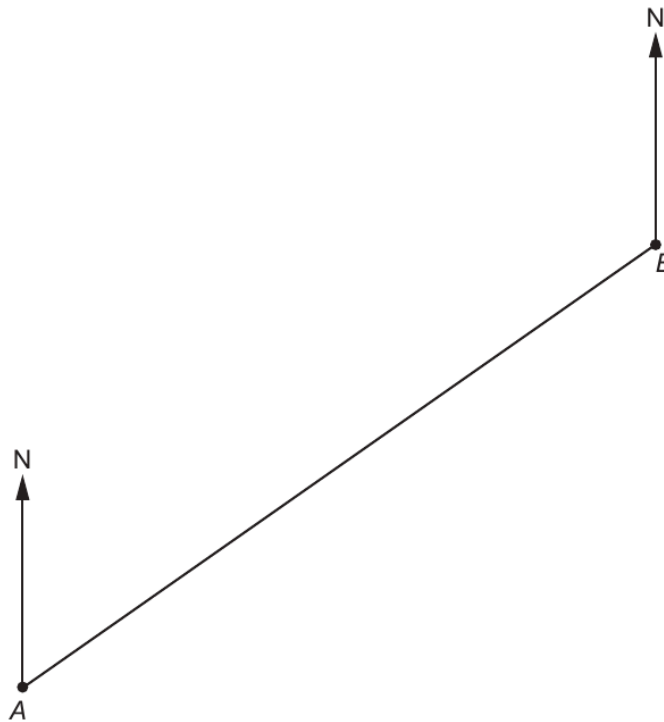

- (b) Use your scale drawing to calculate
- the **actual** length of AC, in kilometres,
 - the bearing of point C from point A.

[2]

.....

.....

Actual length of AC = km

Bearing of point C from point A = °



3300U401
11

11. (a) Enlarge the shape below by a scale factor of 3.

[2] Examiner only

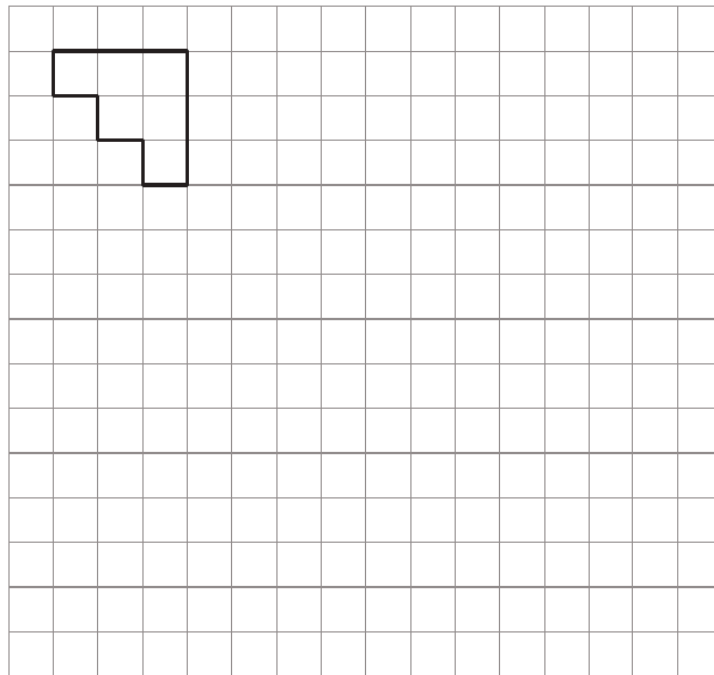

(b) Translate the shape below 2 squares to the left and 4 squares down.

[1]

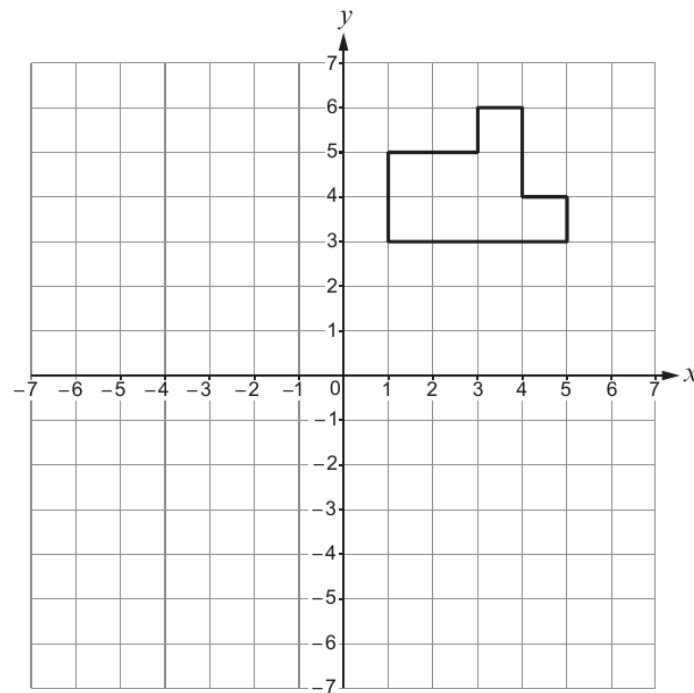

Examiner
only

14. (a) The rectangle below has:
- a length of $3y$
 - a width of $y + a$
 - an area of $3y^2 + 12y$.

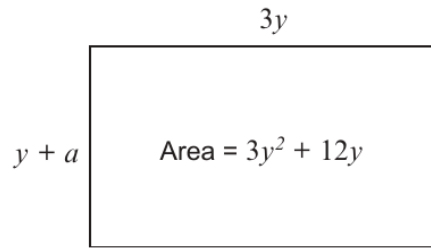

Diagram not drawn to scale

Find the value of a .
You must show all your working.

[3]

.....

.....

.....

.....

.....

.....

.....



Examiner
only

(b) Another rectangle has a width of $4x - 10$.

(i) Given that x is a whole number, explain why the value of x cannot be less than 3. [1]

.....

.....

.....

.....

.....

.....

(ii) The perimeter of the rectangle is $14x - 4$.

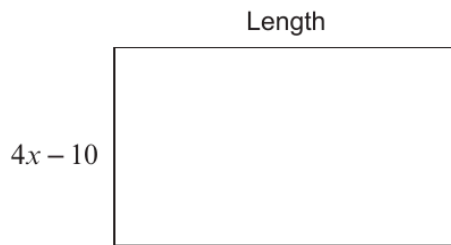

Diagram not drawn to scale

Find the length of the rectangle in **terms of x** . [4]

.....

.....

.....

.....

.....

.....

.....

.....

.....

.....



Examiner
only

15. Andrew and Grace each have some £10 notes and £5 notes.
Andrew has 6 notes. The total value of Andrew's notes is £55.
Grace has 5 notes. The total value of Grace's notes is £35.

How many £10 notes do they have in total?
How many £5 notes do they have in total?

[3]

.....

.....

.....

.....

.....

.....

.....

.....

.....

Total number of £10 notes = Total number of £5 notes =

16. (a) Solve the equation $7p - 3 = 60$.

[2]

.....

.....

.....

.....

.....

.....

(b) Simplify the expression $6a - 7b - 2a - 8b$.

[2]

.....

.....

.....



16. Express 1575 as a product of its prime factors in index form.

[3]

Examiner
only

.....

.....

.....

.....

.....

.....

.....

.....

.....

.....

.....

.....

.....

.....

.....

.....



Examiner only

17. Point A and point B are shown in the scale drawing below.

- (a) Point C is 35 km from point B on a bearing of 300°. Complete the scale drawing to show the position of point C. [2]

Scale: 1 cm represents 5 km

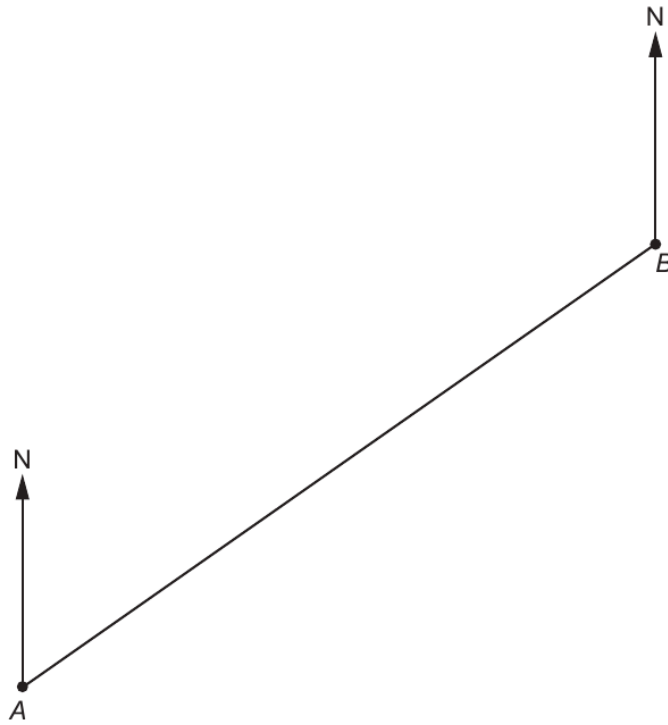

- (b) Use your scale drawing to calculate
- the **actual** length of AC, in kilometres,
 - the bearing of point C from point A.

[2]

.....

.....

Actual length of AC = km

Bearing of point C from point A = °



Examiner
only

13. (a) Solve the equation $3x - 10 = 17$. [2]

.....
.....
.....

(b) Simplify $6f - 4g + 2f - 9g$. [2]

.....
.....
.....

14. (a) Which of the following is nearest in mass to 5 kg?
Circle the correct answer. [1]

- 7 lb 11 lb 15 lb 19 lb 23 lb

.....
.....

(b) Which of the following is nearest in volume to 100 litres?
Circle the correct answer. [1]

- 100 pints 125 pints 150 pints 175 pints 200 pints

.....
.....



Examiner
only

13. (a) Simplify each of the following.
Circle your answer in each case.

(i) $m^4 \times m^3 =$ [1]

- m^7 m^{12} m^{43} $7m$ $12m$
-

(ii) $\frac{m^{15}}{m^5} =$ [1]

- m^{75} $\frac{1}{m^3}$ m^3 m^{10} $\frac{1}{m^{10}}$
-

(b) Write down an expression for the n th term of the following sequence. [2]

- 4, 11, 18, 25,
-
-
-

(c) List all of the integers that satisfy the following inequality. [2]

$$13 < 2n < 19$$

.....

.....

.....

.....

.....

Integers are



Examiner
only

13. Alice is 9 years younger than Isaac.
Nadia is one third of Isaac's age.
Dewi is twice Nadia's age.

Alice is 27 years old.

What are the ages of Isaac, Nadia and Dewi? [3]

.....

.....

.....

.....

.....

.....

.....

.....

.....

Isaac is years old. Nadia is years old. Dewi is years old.

14. (a) Write down the next two numbers in the following sequence. [2]

-26 -20 -14 -8

.....

.....

.....

(b) $f = 3g + 2h$.

Calculate the value of f when $g = 9.3$ and $h = -13.6$. [2]

.....

.....

.....

.....



Examiner
only

14. (a) Evaluate $\frac{\sqrt[3]{154}}{7.9 - 3.26}$.

Give your answer correct to 2 significant figures.

[2]

.....

.....

.....

.....

(b) Calculate the reciprocal of 23.

Give your answer correct to 3 decimal places.

[2]

.....

.....

.....

(c) Circle the correct answer for each of the following.

(i) The Lowest Common Multiple (LCM) of 4 and 6 is:

2 4 6 12 24

[1]

.....

(ii) The Highest Common Factor (HCF) of 10 and 15 is:

5 10 15 30 150

[1]

.....



Examiner
only

5. The map below shows part of South West Wales.



(a) Find the bearing of St Brides from Fishguard. [1]

..... °

(b) The distance by road from Haverfordwest to Milford Haven is 12 km.
(i) Estimate the distance by road from Haverfordwest to Fishguard. [1]

..... km



Examiner
only

- (ii) Owain has a **different** map that has a scale of 1 : 25000.

Owain measures the distance by road from Haverfordwest to Milford Haven on his map.

Complete Owain's statement below.

"On my map, the distance by road from Haverfordwest to Milford Haven is represented by a length of cm." [3]

.....

.....

.....

.....

.....

.....

3310U301
11



Examiner
only

9. The map below shows part of South West Wales.



(a) Find the bearing of St Brides from Fishguard. [1]

..... °

(b) The distance by road from Haverfordwest to Milford Haven is 12 km.
(i) Estimate the distance by road from Haverfordwest to Fishguard. [1]

..... km



Examiner
only

- (ii) Owain has a **different** map that has a scale of 1 : 25 000.

Owain measures the distance by road from Haverfordwest to Milford Haven on his map.

Complete Owain's statement below.

"On my map, the distance by road from Haverfordwest to Milford Haven is represented by a length of cm." [3]

.....

.....

.....

.....

.....

.....

END OF PAPER



Examiner
only

12. The diagram below shows the positions of three points *A*, *B* and *C* on a map.
The diagram is drawn to scale.

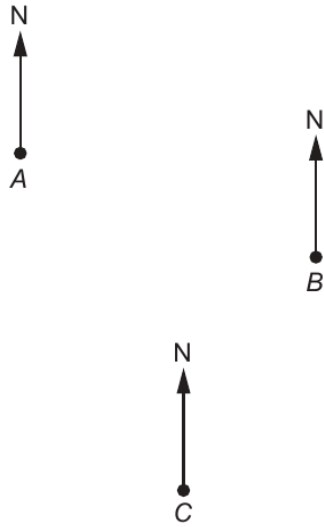

(a) Find the bearing of *B* from *A*. [1]

.....

.....

.....

.....

(b) Find the bearing of *A* from *C*. [1]

.....

.....

.....

.....



Examiner
only

13. A **decimal** number is written on a card.
You have three clues to help you work out the number on the card.
Clue 1: The number is between 5 and 12 inclusive.
Clue 2: The number is a multiple of 2·3.
Clue 3: The square of the number is greater than 50 but less than 120.

What is the decimal number on the card? [2]

.....

.....

.....

.....

.....

.....

.....

.....

The decimal number on the card =



Examiner
only

14. (a) Find $\frac{3}{7}$ of 9·17 km.

Give your answer in metres.

[3]

.....

.....

.....

.....

.....

.....

.....

..... metres

(b) Express 25 minutes as a percentage of 2 hours 5 minutes.

[3]

.....

.....

.....

.....



Examiner
only

14. (a) £285 is decreased by 4%.
This is done 3 times in total.
Each time, the previous value is decreased by 4%.
What calculation would you use to find the value after the 3 decreases?
Circle your answer. [1]

$£285 \times 1.04^3$ $£285 \times 0.04^3$ $£285 \times 0.96^3$ $£285 \times 0.6^3$ $£285 \times 0.96^2$

.....
.....

- (b) A number has been decreased by 10% to give an answer of 34.2.
What was the original number? [2]

.....
.....
.....
.....
.....



Examiner
only

1. Solve each of the following equations.

(a) $\frac{x}{5} = 20$

[1]

.....
.....

(b) $7m + 3 = 31$

[2]

.....
.....
.....

2. (a) Evaluate 55% of 42.8.

[2]

.....
.....
.....

(b) Which one of the following is **not** equal to a recurring decimal?
Circle the correct answer.

[1]

- $\frac{2}{11}$ $\frac{2}{3}$ $\frac{3}{16}$ $\frac{7}{9}$ $\frac{5}{6}$

.....
.....
.....

3300U401
03



Examiner
only

5. (a) Siôn has an ice cream van.

On Monday, Siôn sold three times as many ice creams
as cold drinks.
He sold 50 cold drinks on Monday.
Siôn sells ice creams for £1.80 each.



Calculate the amount of money Siôn took from selling ice creams on Monday. [4]

.....

.....

.....

.....

.....

.....

.....

(b) Siôn keeps ice cream in a freezer in his van.
Every hour he checks the temperature in his freezer.
He turns on his freezer at 8 a.m.
The readings he takes from 8 a.m. to 3 p.m. are listed below.

10°C 2°C -5°C -12°C -12°C -12°C -13°C -14°C

(i) Calculate the mean of these temperatures. [3]

.....

.....

.....

.....

.....

.....

(ii) At 4 p.m. the temperature in Siôn's freezer was recorded as -16°C.
Calculate the mean of the temperatures recorded in Siôn's freezer from 8 a.m. to
4 p.m. [2]

.....

.....

.....



Examiner only

(c) Siôn parks his ice cream van on the beach, as shown on the map below.

Scale: 1 cm represents 20 metres

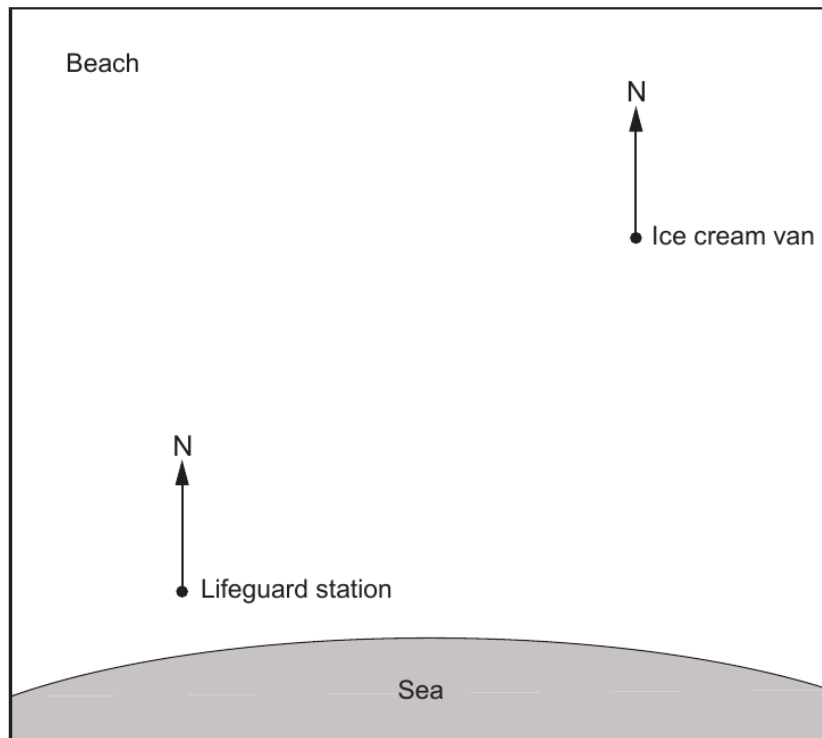

(i) How far is Siôn's ice cream van from the lifeguard station? [2]

.....
.....

..... metres

(ii) Complete the following statement.

'The bearing of the lifeguard station from Siôn's ice cream van
is°'

[1]

.....
.....

3310U301
09



6. Erin owns a small shop.
Last year, Erin's income from her shop was 26 000 euros.
Erin had to pay tax on all of this income.
She paid 20% tax on the first 15 000 euros of this income.
She paid 30% tax on the rest of this income above 15 000 euros.

Calculate how much tax Erin paid in total.
You must show all your working.

[5]

Examiner
only

.....

.....

.....

.....

.....

.....

.....

.....



Examiner only

7. (a) Josif produces a scale drawing to show where he wants a tree planted in his garden.

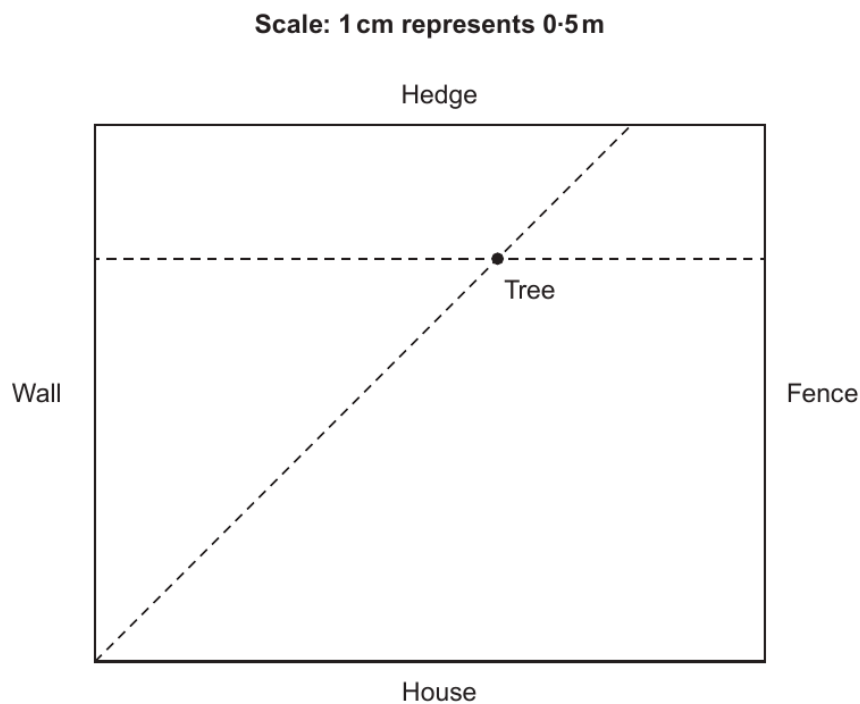

He writes out instructions to show where the tree is to be planted.

Which **two** of the following instructions describe where the tree is to be planted?

- A. The tree must be 2 m from the hedge.
- B. The tree must be 1 m from the hedge.
- C. The tree must be 6 m from the hedge.
- D. The tree must be 3 m from the hedge.
- E. The tree must be 1 m from the wall.

- F. The tree must be equidistant from the hedge and the fence.
- G. The tree must be equidistant from the hedge and the wall.
- H. The tree must be equidistant from the wall and the house.
- I. The tree must be equidistant from the hedge and the house.
- J. The tree must be equidistant from the wall and the fence.

[2]

.....

.....

The two instructions are and



Examiner
only

- (b) A garden centre buys trees from a grower for £30 each.
The garden centre sells the trees for £42 each.



- (i) Calculate the percentage profit the garden centre makes from buying and selling one tree. [2]

.....

.....

.....

- (ii) The garden centre buys 10 of these trees to sell.
One of the trees gets damaged and cannot be sold.
The other 9 trees are sold.
Calculate the overall percentage profit or loss the garden centre makes from selling these trees.
You must state whether your answer is a profit or a loss.
You must show all your working. [4]

.....

.....

.....

.....

.....

.....

- (iii) Of the 10 trees bought by the garden centre, what is the minimum number that need to be sold to ensure that the garden centre makes a profit?
Circle your answer. [1]

5 6 7 8 9

.....

.....



Examiner
only

9. Solve each of the following equations.

(a) $\frac{x}{5} = 20$

[1]

.....
.....

(b) $7m + 3 = 31$

[2]

.....
.....
.....
.....

10. Evaluate 55% of 42.8.

[2]

.....
.....
.....



Examiner
only

9. (a) Siôn has an ice cream van.

On Monday, Siôn sold three times as many ice creams as cold drinks.
He sold 50 cold drinks on Monday.
Siôn sells ice creams for £1.80 each.



Calculate the amount of money Siôn took from selling ice creams on Monday. [4]

.....

.....

.....

.....

.....

.....

.....

(b) Siôn keeps ice cream in a freezer in his van.
Every hour he checks the temperature in his freezer.
He turns on his freezer at 8 a.m.
The readings he takes from 8 a.m. to 3 p.m. are listed below.

10°C 2°C -5°C -12°C -12°C -12°C -13°C -14°C

(i) Calculate the mean of these temperatures. [3]

.....

.....

.....

.....

.....

.....

(ii) At 4 p.m. the temperature in Siôn's freezer was recorded as -16°C.
Calculate the mean of the temperatures recorded in Siôn's freezer from 8 a.m. to 4 p.m. [2]

.....

.....



Examiner
only

(c) Siôn parks his ice cream van on the beach, as shown on the map below.

Scale: 1 cm represents 20 metres

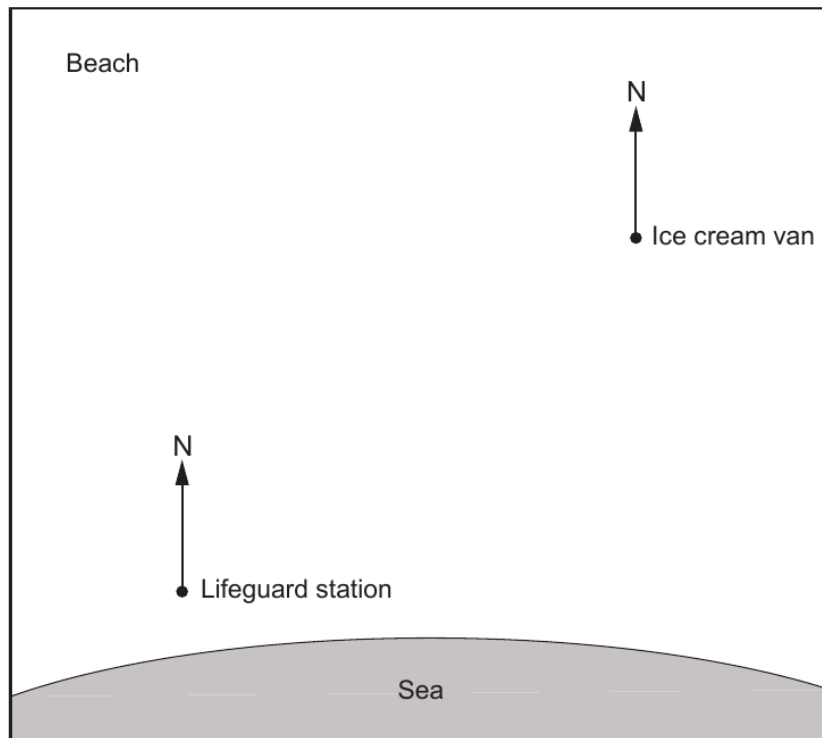

(i) How far is Siôn's ice cream van from the lifeguard station? [2]

.....
.....

..... metres

(ii) Complete the following statement.

'The bearing of the lifeguard station from Siôn's ice cream van
is°'

[1]

.....
.....

END OF PAPER



Examiner
only

11. ABC is a large triangle, where $AC = 16\text{ m}$ and $BC = 13\text{ m}$.

(a) Draw a scale drawing of this triangle using the following scale:

1 cm represents 2 m.

The side AB has already been drawn accurately.

[2]



(b) What is the size of \hat{ACB} ?

[1]



Examiner
only

13. (a) Which of the following is the nearest value to 488 grams?
Circle the correct answer. [1]

0.5 kg 500 kg 50 kg 5 tonnes 0.05 kg

.....

(b) Circle the correct answer for the following. [1]
15 miles is approximately equal to

1500 m 24 km 15 km 2.4 km 3000 m

.....

.....

.....

14. The n th term of a sequence is given by $5n - 1$.
Calculate the sum of the first three terms.
You must show all your working. [3]

.....

.....

.....

.....

.....

.....

Sum of the first three terms =



Examiner
only

13. The table below shows some of the values of $y = 2x^2 + 5x - 3$ for values of x from -4 to 2 .

x	-4	-3	-2	-1	0	1	2
$y = 2x^2 + 5x - 3$	9	0	-5	-6	-3		15

(a) Complete the table above. [1]

.....

.....

(b) On the graph paper opposite, draw the graph of $y = 2x^2 + 5x - 3$ for values of x from -4 to 2 . [2]

(c) Draw the line $y = 6$ on the graph paper.
Write down the values of x where the line $y = 6$ cuts the curve $y = 2x^2 + 5x - 3$. [2]

Values of x are and



19. (a) Reflect the shape A in the line $x = -1$.

[2]

Examiner
only

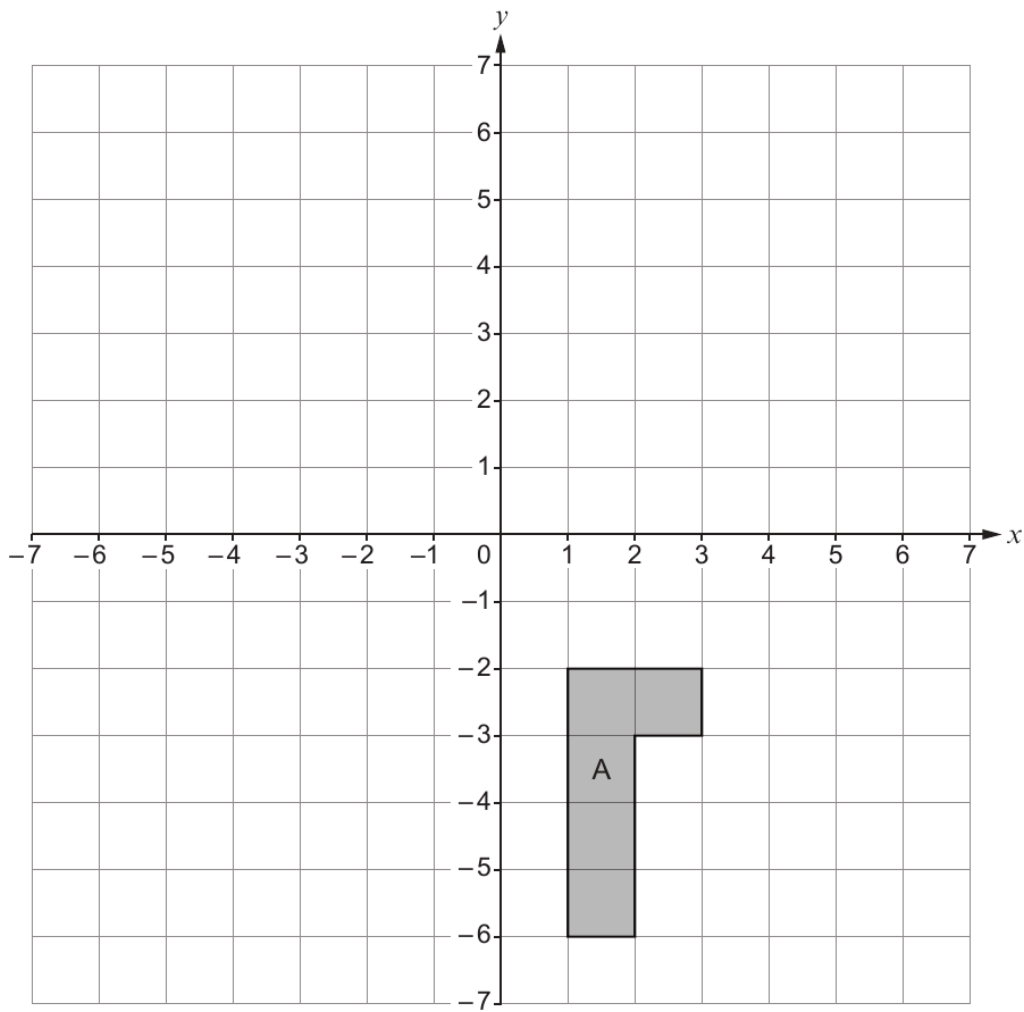

(b) Enlarge the shape B by a scale factor of 2, using (1, 3) as the centre of enlargement. [3]

Examiner
only

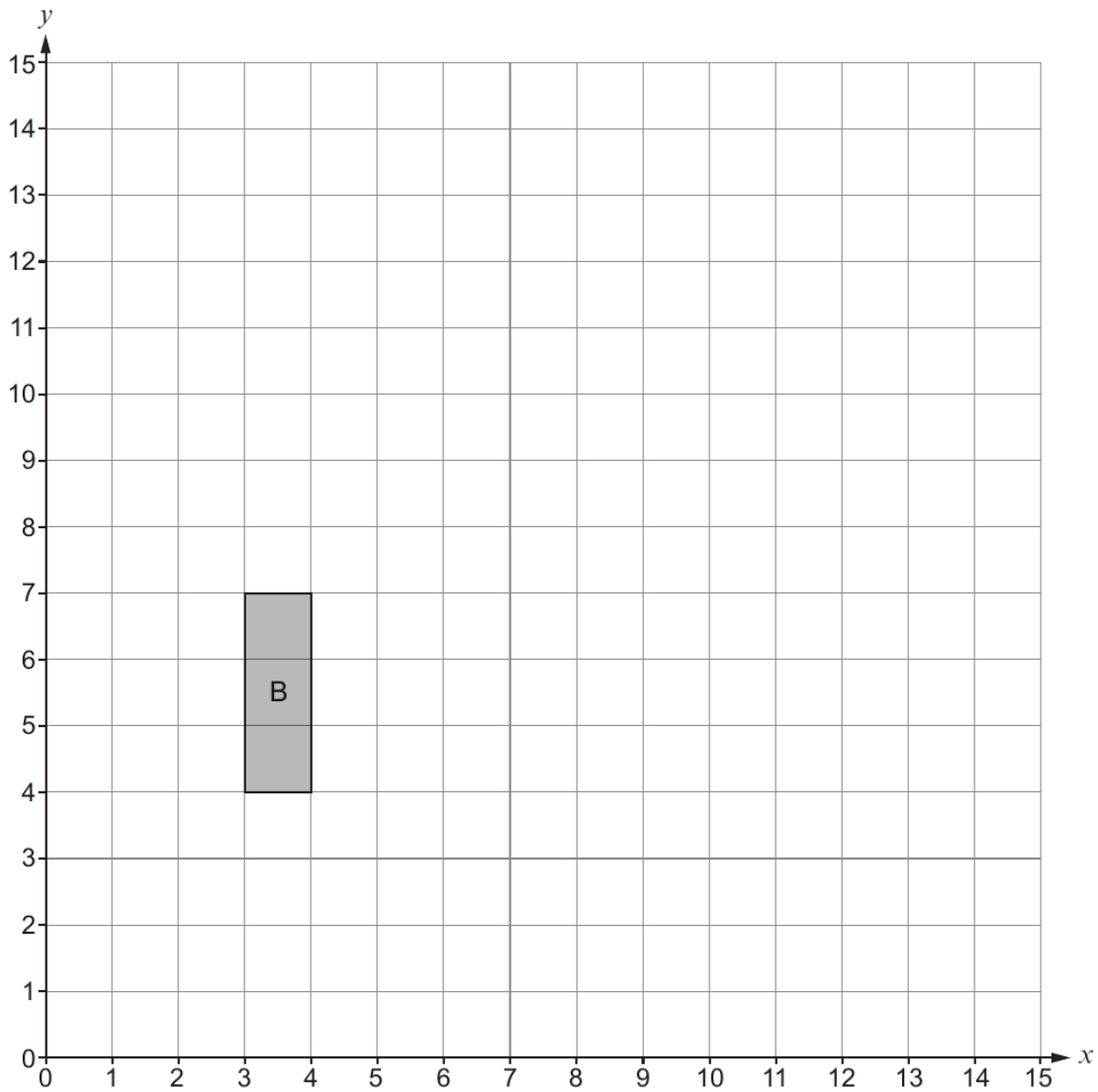

END OF PAPER



Examiner
only

3. (a) Magic Johnson is one of the greatest basketball players of all time.



- He first played for the LA Lakers in 1979.
- His height is 206 cm.
- His salary in 1989 was \$3 142 000.

(i) How many years ago did Magic Johnson first play for the LA Lakers? [1]

.....

.....

.....

.....

(ii) What is Magic Johnson's height in metres? [1]

.....

.....

(iii) Write his salary of \$3 142 000 in words. [1]

.....

.....

.....

(b) Which of the following is the best description for the shape of a basketball?
Circle your answer.

- Sphere Cylinder Cuboid Cone Cube

[1]



Examiner
only

- (c) A local basketball club trains on a basketball court each week.
The basketball court is rectangular.
The diagram below is a **scale drawing** of the basketball court.

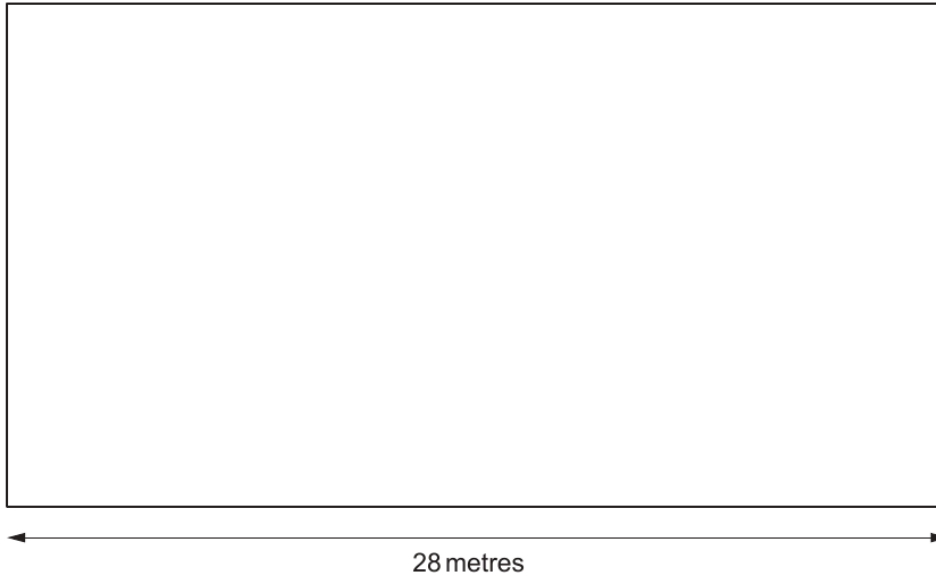
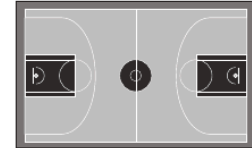

The **actual length** of the basketball court is 28 metres.
Use the scale drawing to find the **actual width** of the basketball court.

[3]

.....

.....

.....

.....

Actual width of the basketball court is metres



Examiner
only

(d) The diagram below represents the positions of three players on a basketball court.

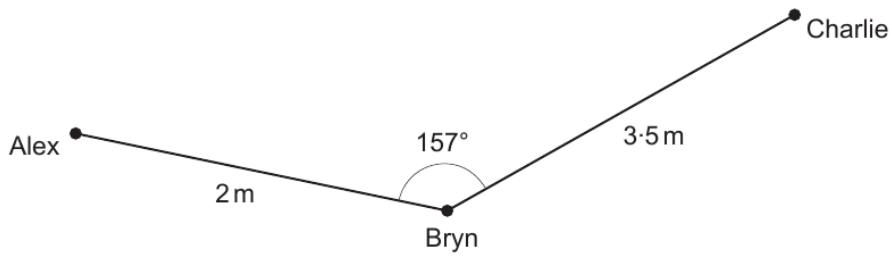

Diagram not drawn to scale

- (i) Bryn faces Alex.
Bryn then turns clockwise to face Charlie.

Charlie thinks that Bryn has turned through an acute angle.

Do you agree?

Give a reason for your answer.

[1]

Yes No

.....
.....

- (ii) In the space below, complete an **accurate scale drawing** to show Charlie's position.

The positions of Alex and Bryn are shown.

Use the scale: 1 cm represents 0.5 m.

[2]

.....



Examiner only

4. (a) The map below shows part of the coastline and some islands off the coast of Gwynedd.



(i) Write down the bearing of Aberdaron from Bardsey Island lighthouse. [1]

..... °

(ii) Write down the bearing of Bardsey Island lighthouse from Ynys Gwylan-bach. [1]

..... °

(iii) How can you see Bardsey Island lighthouse from Ynys Gwylan-bach. How far is the lighthouse from Ynys Gwylan-bach? Give your answer in **kilometres**. You must show all your working. [2]

.....
.....
.....
.....



Examiner
only

(b) The candela and the lumen are units that can be used to measure light intensity.

Below is a conversion graph.

You can use this graph to make approximate conversions between candelas and lumens for a particular type of light.

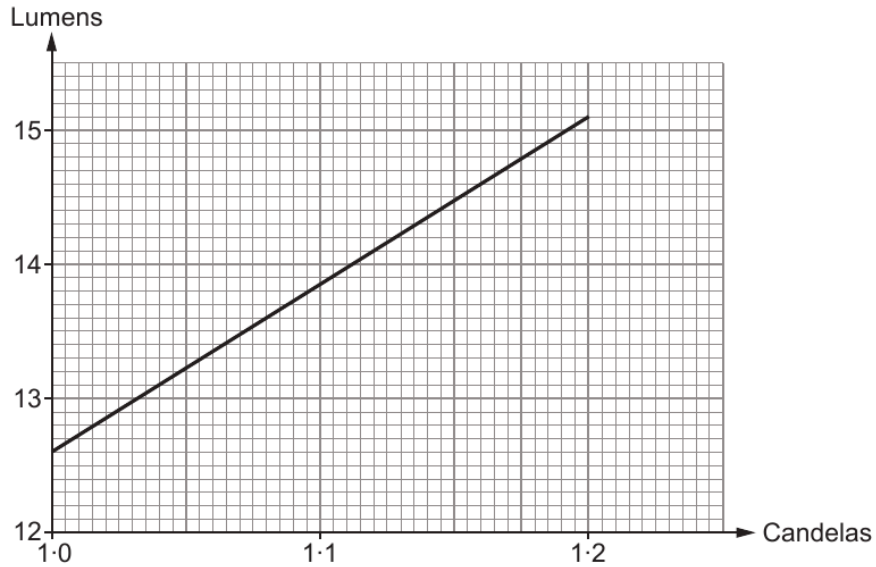

For this type of light, complete each of the following statements.

- (i) 1.15 candelas is approximately equal to lumens. [1]
- (ii) 13.5 lumens is approximately equal to candelas. [1]

(c) The light from Bardsey Island lighthouse has an intensity of approximately 52 000 candelas.
The light from Strumble Head lighthouse in Pembrokeshire has an intensity of approximately 1 000 000 candelas.

By estimating, complete the following statement.
You must show all your working. [2]

'The light from Strumble Head lighthouse is approximately times as intense as the light from Bardsey Island lighthouse.'

.....

.....

.....

.....



Examiner
only

10. (a) Delia invests £4000 in an account that pays 3% compound interest per annum. She does not withdraw money or make any other payments into her account.

How much will Delia have in her account after **two years**? [3]

.....

.....

.....

.....

.....

.....

.....

.....

Amount in Delia's account after two years £

- (b) Delia bought a gold bracelet at a car boot sale a few years ago.

- (i) Delia's bracelet has increased in value by 40%.
Her gold bracelet is now worth £42.

Calculate how much Delia paid for the bracelet in the car boot sale. [2]

.....

.....

.....

.....

.....

Delia paid £



- (ii) The density of the gold in Delia's bracelet is 20 g/cm^3 .
The bracelet has a mass of 6×10^{-3} **kilograms**.

Calculate the volume of Delia's bracelet.
Give your answer in cm^3 .

[3]

Examiner
only

.....

.....

.....

.....

.....

.....

.....

.....



Examiner
only

13. Bethan has two brothers, Andrew and Richard.

Andrew is 7 years older than Bethan.
Richard is 3 years older than Andrew.

- (a) Today, the sum of all their ages is 59 years.
How old are Bethan, Andrew and Richard today? [2]

.....

.....

.....

.....

.....

.....

.....

.....

Bethan = years old
Andrew = years old
Richard = years old

- (b) (i) Write down the ratio of Andrew's age to Richard's age when Andrew is 27.
Write the ratio in its simplest form. [2]

.....

.....

.....

Ratio of Andrew's age to Richard's age = :

- (ii) Explain why the ratio of Andrew's age to Richard's age can never be 1 : 1. [1]

.....

.....

.....



Examiner
only

13. A cyclist travels for 2 hours at an average speed of x miles per hour.
She then travels for a further 3 hours at an average speed of $(x + 6)$ miles per hour.
She travels a total distance of 78 miles.

Form an equation, in terms of x , to represent the total distance she travels.
Solve your equation and use your solution to complete the statements below.

[6]

.....

.....

.....

.....

.....

.....

.....

.....

.....

.....

.....

.....

.....

.....

.....

.....

.....

.....

.....

.....

.....

.....

First, the cyclist travels for 2 hours at an average speed of miles per hour.

Then, she travels for a further 3 hours at an average speed of miles per hour.

